

Undervalued growth stock

Credit card payment and fraud detection solutions specialist transforming profit structure as cloud services turn profitable

SUMMARY

- IWI's core business is the development and maintenance of network connection systems (FEP front-end processor) for credit card authorization, and it holds a dominant share of the market in Japan (SIR estimates 70-80% share). It also develops and maintains proprietary credit card fraud detection systems. Due to the high growth in credit card business in Japan, in part due to national policy promoting the achievement of a cashless society and diversification of payment methods, as well as declining transaction charges, the business opportunity for IWI payment solutions business is expanding to include many new entrants starting up credit card business.
- One hurdle for these prospective customers is the high initial installation cost for an in-house system under the FEP on-premise model. IWI's priority medium-term strategy is to establish a hybrid model adding SaaS cloud services. The advantage of the cloud services model for the customer is an affordable scheme to lease the services, fixing running costs including maintenance. The advantage for IWI is securing a stream of recurring (stock) revenue going forward, which is scalable. Cloud services business turned profitable in FY22/6 (year six) on leading development costs peaking out and realizing operational efficiency gains on increased contracts.
- On fundamentals, the P/E and EV/EBITDA are trading on 21% and 20% discounts to historical averages, respectively, and the DY of 2.82% is 20% above its historical average, in part reflecting the revised 40% payout policy. OPM is set to top 15% in FY24/6, drawing further attention to this undervalued growth stock.

Credit card business is growth business: METI monthly trend of total transactions

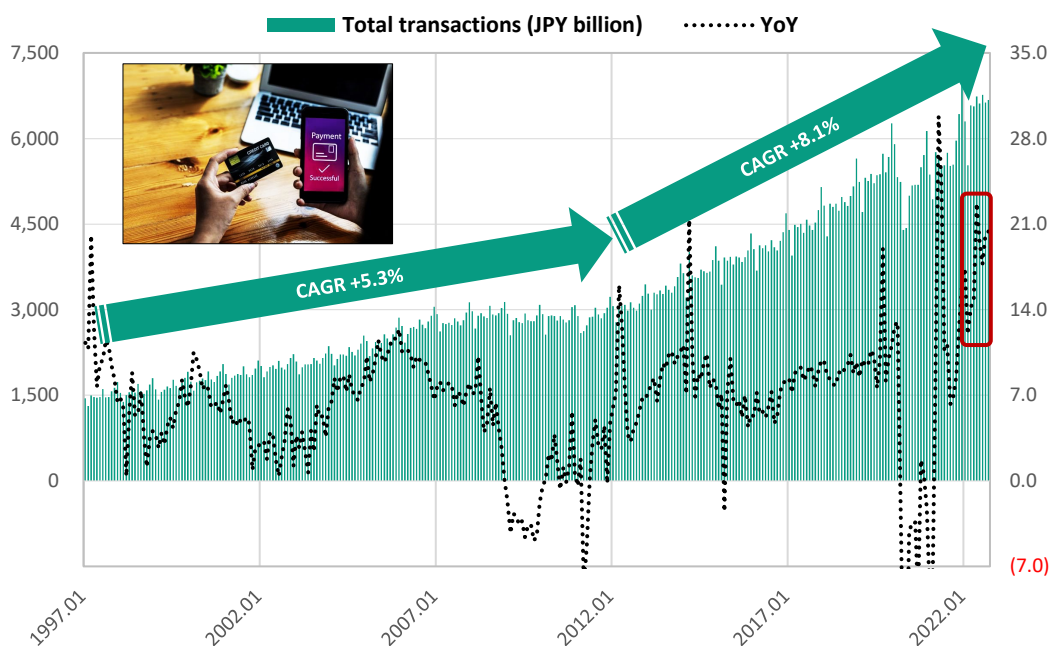

Source: compiled by SIR from "METI Monthly Survey of Specified Service Industries: Credit Cards."

Full Report



Focus Points:

Systems integrator boasting an overwhelming share with credit card companies in FEP systems development for nonstop secure datacenter connection packages.

Key Indicators

Share price (3/7)	712
YH (22/8/31)	924
YL (22/1/27)	490
10YH (18/10/24)	1,180
10YL (14/2/5)	239.0
Shrs out. (mn shrs)	26.34
Mkt cap (¥ bn)	18.701
EV (¥ bn)	14.322
Equity ratio (12/31)	64.8%
23.6 P/E (CE)	14.6x
23.6 EV/EBITDA (CE)	5.1x
22.12 P/B (act)	2.29x
22.6 ROE (act)	13.5%
23.6 DY (CE)	2.82%

6M price chart (weekly)

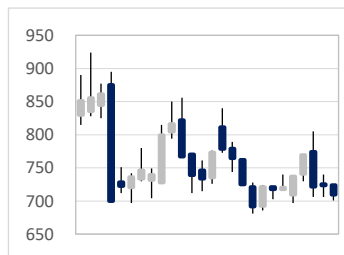

Source: SPEEDA price data

Chris Schreiber CFA

Company Specialist

research@sessapartners.co.jp



This report was prepared by Sessa Partners on behalf of INTELLIGENT WAVE INC. Please refer to the legal disclaimer at the end for details.

INTELLIGENT WAVE INC. Financial Highlights Summary

JPY mn, % [J-GAAP]	FY2011/6	FY2012/6	FY2013/6	FY2014/6	FY2015/6	FY2016/6	FY2017/6	FY2018/6	FY2019/6	FY2020/6	FY2021/6	FY2022/6	FY2023/6
	cons act.	cons act.	cons act.	cons act.	cons act.	cons act.	NC act.*	NC act.	NC act.	NC act.	NC act.	NC act.	init CE
Net sales	4,763	5,242	5,871	6,558	6,160	7,207	8,470	10,604	10,443	10,921	11,188	11,493	13,500
YoY	(3.9)	10.1	12.0	11.7	(6.1)	17.0	17.5	25.2	(1.5)	4.6	2.4	2.7	17.5
Gross profit	1,642	1,374	473	1,342	1,779	1,993	2,132	2,223	2,807	2,981	3,157	3,699	
ratio to sales (%)	34.5%	26.2%	8.1%	20.5%	28.9%	27.7%	25.2%	21.0%	26.9%	27.3%	28.2%	32.2%	
SG&A expenses	1,321	1,243	1,151	1,196	1,295	1,279	1,430	1,675	1,885	1,944	2,026	2,179	
ratio to sales (%)	27.7%	23.7%	19.6%	18.2%	21.0%	17.7%	16.9%	15.8%	18.1%	17.8%	18.1%	19.0%	
Depreciation	72	107	131	190	256	214	337	485	708	606	751	829	1,000
EBITDA	393	238	(547)	336	740	928	1,040	1,033	1,629	1,642	1,882	2,349	2,800
ratio to sales (%)	8.2%	4.5%	-9.3%	5.1%	12.0%	12.9%	12.3%	9.7%	15.6%	15.0%	16.8%	20.4%	20.7%
Operating profit (loss)	321	132	(678)	146	484	714	703	548	922	1,036	1,131	1,520	1,800
YoY	(10.3)	(59.0)	TR	TB	232.8	47.5	(1.6)	(22.0)	68.3	12.5	9.1	34.4	18.4
ratio to sales (%)	6.7%	2.5%	-11.5%	2.2%	7.9%	9.9%	8.3%	5.2%	8.8%	9.5%	10.1%	13.2%	13.3%
Ordinary profit (loss)	342	155	(587)	184	490	731	766	574	954	1,075	1,171	1,556	1,840
Profit (loss)	129	270	(349)	87	471	479	547	377	684	762	841	1,056	1,280
Cash & deposits + secs	2,783	2,808	2,085	2,420	2,957	2,852	2,578	2,840	3,255	3,642	4,308	4,233	
ST/LT lease obligations	0	44	39	28	29	136	102	110	74	39	16	6	
Net IBD (net cash)	(2,783)	(2,764)	(2,046)	(2,392)	(2,928)	(2,716)	(2,476)	(2,730)	(3,181)	(3,603)	(4,292)	(4,227)	
Total assets	5,717	6,363	5,755	5,640	6,482	7,027	8,508	8,837	10,032	10,552	11,140	12,741	
Current assets	3,822	4,335	3,560	3,524	4,560	4,682	4,985	5,256	6,054	6,381	6,976	8,274	
Non-current assets	1,895	2,028	2,195	2,116	1,921	2,345	3,523	3,581	3,978	4,171	4,164	4,467	
Total liabilities	1,011	1,443	1,308	1,188	1,647	1,964	2,861	3,122	3,660	3,569	3,572	4,702	
Current liabilities	765	1,147	1,007	881	1,150	1,373	2,252	2,523	3,058	2,951	2,912	4,036	
Non-curr. liabilities	246	296	301	307	497	591	609	599	601	618	661	666	
Total net assets	4,706	4,920	4,447	4,451	4,835	5,063	5,648	5,715	6,373	6,983	7,568	8,039	
CFO	795	252	(588)	620	839	124	1,173	1,213	1,237	1,547	1,700	1,486	
CFI	(61)	(25)	3	(47)	(263)	(192)	(1,151)	(604)	(602)	(753)	(743)	(1,516)	
CFF	(132)	(138)	(142)	(142)	(143)	(34)	(199)	(349)	(220)	(408)	(292)	(351)	
Free cash flow (FCF)	734	227	(585)	573	576	(68)	22	609	635	794	957	(30)	
Equity ratio	82.3	77.3	77.3	78.9	74.6	72.1	66.4	64.7	63.5	66.2	67.9	63.1	
ROE	2.8	5.6	(7.5)	2.0	10.1	9.7	10.3	6.6	11.3	11.4	11.6	13.5	
Dividend payout ratio	102.3	48.9	0.0	151.7	28.0	33.0	33.6	48.8	34.6	34.5	40.7	42.3	
Shares out. (000)	263.4	263.4	263.4	26,340	26,340	26,340	26,340	26,340	26,340	26,340	26,340	26,340	
Treasury shares (000)	0	0	0	0	0	0	12.0	23.8	31.9	41.7	50.1	56.9	
EPS (¥) adj.	4.92	10.27	(13.25)	3.29	17.89	18.18	20.78	14.36	25.99	29.00	31.98	40.16	48.70
DPS (¥) adj.	5.00	5.00	5.00	5.00	5.00	6.00	7.00	7.00	9.00	10.00	13.00	17.00	20.00
BPS (¥) adj.	178.66	186.80	168.84	169.00	183.55	192.21	214.51	217.18	242.23	265.55	287.85	305.87	
Employees (persons)	273	272	282	286	302	315	339	397	413	435	441	449	

Source: compiled by SIR from YUHO financial statements and SPEEDA earnings database. NC = non-consolidated, TR = turned red, TB = turned black.

*FY17/6 YoY figures provided for reference only. FY23/6 depreciation est. by SIR.

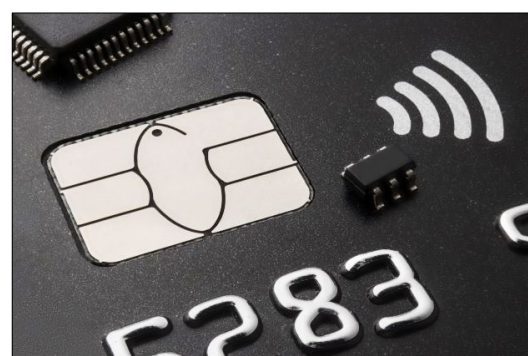

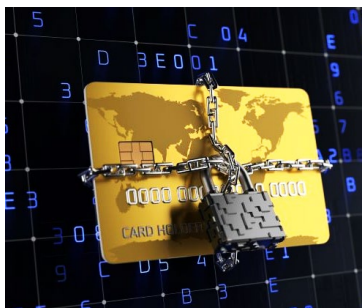
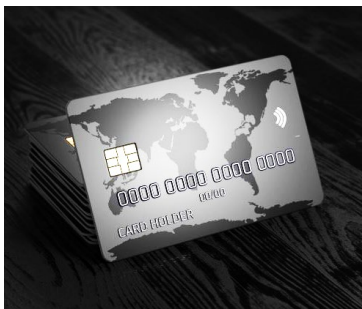

Table of Contents

- 1 BACKGROUND: Credit card business is growth business 4
- 2 BUSINESS: Business description and evolving hybrid model 10
- 3 EARNINGS: 1Q FY23/6 financial results and rolling MTP forecasts 19
- 4 INVESTORS: Share price, valuations and shareholder rebates 24
- SUPPLEMENT: Non-consolidated balance sheets, corporate history 26



Credit card payment and fraud detection systems solutions specialist



INTELLIGENT WAVE INC. profit structure is shifting upward into a new level

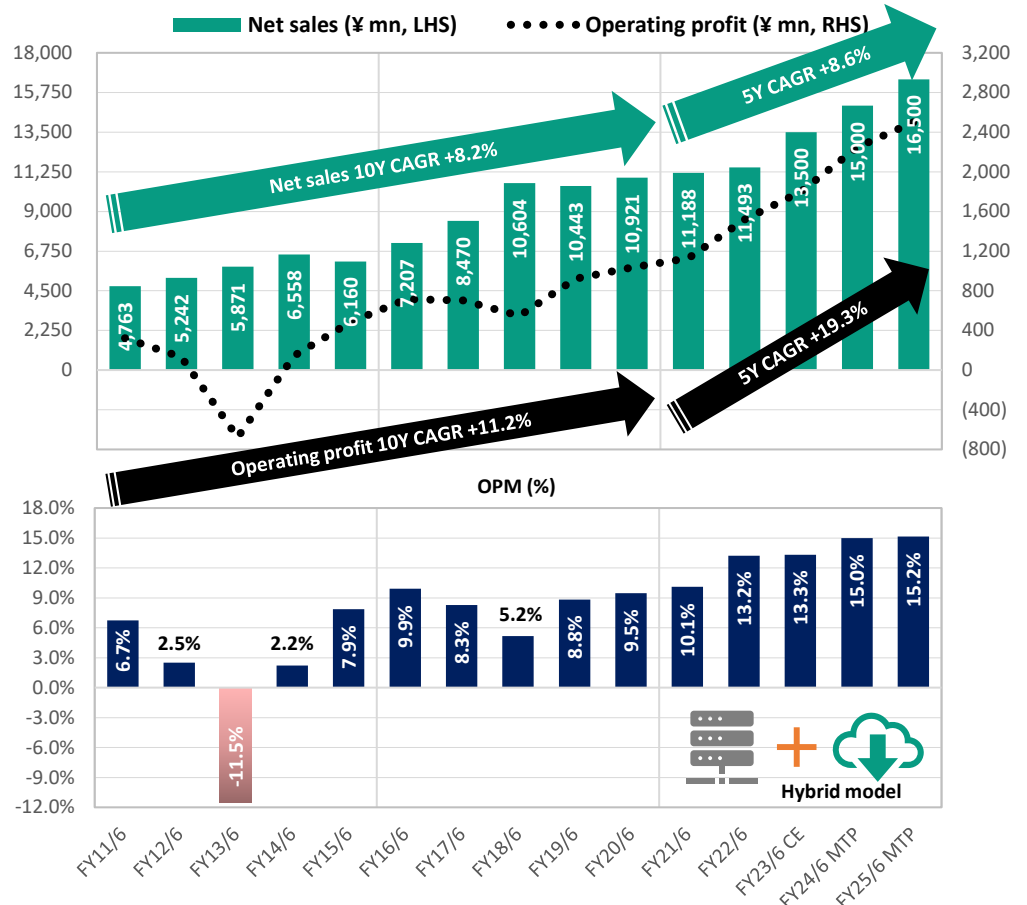

Source: compiled by SIR from IR results briefing materials.



PART 1
BACKGROUND

Credit card business is growth business – transaction process basics

IWI is a system integrator (provider of specific application solutions including a combination of software and hardware) focused on systems for financial services. IWI’s core business is the development and maintenance of network connection systems (FEP front-end processor) for credit card settlement, and it holds a dominant share of the market in Japan. It also develops and maintains proprietary credit card fraud detection software. We examine IWI’s business in detail in PART 2. In PART 1, we focus on a brief overview of the credit card transaction process, national policy to raise the cashless payments ratio in Japan driving high growth in credit card transactions, and the growth trend in global credit card transactions as well as loss damage from fraud.

In order to understand what IWI’s FEP systems for payment network connection and authorization packages actually do, it may be useful to review the basic process of online credit card payment authorization. The diagram below highlights the key parties involved in a credit card transaction. All credit card transactions involve two different banks—one representing the cardholder, known as the issuing bank, and one representing the merchant, called the acquiring bank. The acquiring bank maintains the merchant’s bank account. The contract with the acquirer enables merchants to process credit and debit card transactions.

The acquiring bank passes the merchant’s transactions along to the applicable issuing banks to receive payment. The issuing bank issues credit cards to consumers on behalf of the branded card networks (Visa, MasterCard, etc). The issuer acts as the middle-man for the consumer and the card network by contracting with the cardholders for the terms of repayment for transactions. Sometimes a payment processor and acquiring bank are the same, however in many cases the processor is a third-party payment services provider (PSP), which allow merchants to accept a wide range of payment methods.

The process for payment by credit card has three main stages: 1) authorization, 2) clearing and 3) settlement. For 1) authorization, card information is forwarded by the merchant to the acquirer, often through the processor (PSP), then through the card network to the issuer. The issuing bank confirms the card is valid and sufficient funds or credit are available to complete the payment. The issuer then sends a response back

Credit card transaction process overview

★ IWI core business is focused on the authorization stage

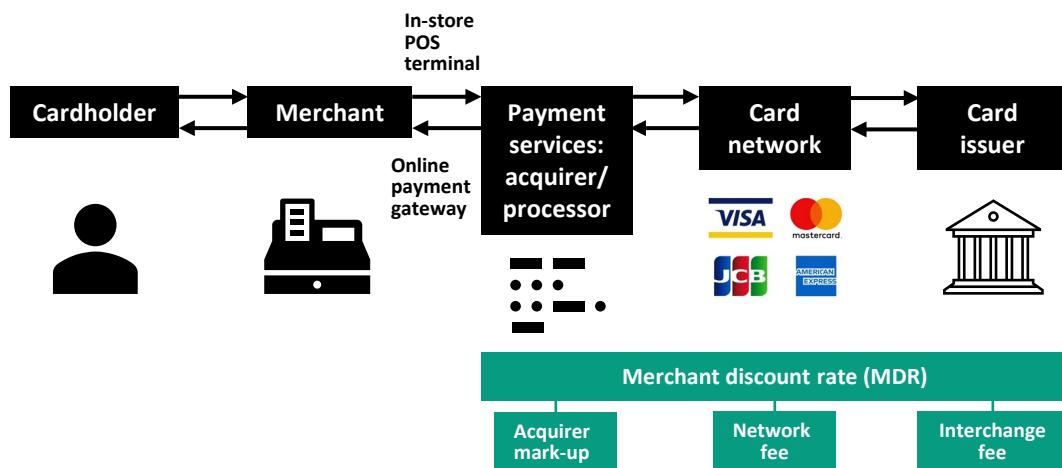

Source: compiled by SIR



to the acquirer, either approved with an authorization code, or declined with an error code. The merchant receives the authorization from the acquirer via the processor (PSP), and then fulfills the purchase transaction with the cardholder. **The key point is this entire multi-step authorization process is completed in just seconds.** For 2) clearing, merchants batch the approved transactions at the end of the day, which are forwarded by the acquirer to the issuer through the card networks. The issuing bank deducts the corresponding transaction amount from the customer's account and routes the payment back through the card networks to the acquirer. For 3) settlement, the acquirer deposits the amount into the merchant's account, finalizing a transaction.

IWI's core business is focused on stage 1) authorization. SIR estimates IWI has a 70-80% overwhelming share in the market for IWI's flagship product Net+1 authorization center connection package, and optional service ACE Plus for detecting fraudulent credit card use.

- 100% fault tolerant (system redundancy w/ backup CPUs/processes) non-stop server systems with always-on OS to ensure 24/7 availability
- Ultra-low latency for real-time response

- Request authorization
- Approve / decline

• Since an overwhelming majority of major domestic credit card companies are IWI customers, it is estimated that almost all credit card payment transactions in circulation in Japan are processed by IWI's FEP.

We examine the history of how the company was able to capture such a high market share in PART 2, which has important implications such as high barriers to entry due to the installed base, as well as being a relatively small niche market that is not worth the investment cost of a major SI player trying to enter. According to the company, FEP systems are replaced every 5-6 years, so there is also an element of recurring stock business, providing medium-term stability. **IWI management is now focused on the business opportunity from developing cloud service versions of these technologies, targeting other entities such as commercial enterprises and regional banks interested in starting a credit card business.**

Regarding the business opportunity from structural growth in the credit card industry, the graphic on the left provides a useful way to characterize the linkage between the long-term growth outlook and IWI FEP orders. To be clear, there is no direct benefit to a system integrator like IWI from high structural growth in credit card transaction value per se. However, the fact that credit card business is a growth business is supporting growth in credit card capex. **Credit card capex is the primary driver for IWI FEP orders.**

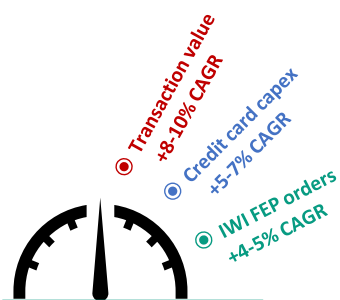

Growth linkage: Credit card capex is the primary driver of IWI FEP orders

Source: compiled by SIR based on IR handout materials. Note: growth estimates added by SIR based on IR interviews.



★ Many of these top credit card issuers are IWI clients

Representative Credit Card Issuers in Japan by Sector

Banks	Mitsubishi UFJ NICOS Co.,Ltd. Sumitomo Mitsui Card Co., Ltd.
Retail	Credit Saison Co., Ltd. AEON Credit Service Co, Ltd. MICARD Co., LTD (Mitsukoshi Isetan) Rakuten Card Co., Ltd. YJ Card Corporation (Yahoo! Japan) Pocket Card Co., Ltd. Seven Card Service Co., Ltd
Consumer Finance	Orient Corporation APLUS FINANCIAL CO., LTD Life Card Co., Ltd. JACCS CO., LTD.
Commerce	Toyota Finance d Card (NTT DoCoMo) JALCARD Viewcard Co., Ltd. (JR East)

Source: compiled by SIR

Credit card business is growth business – Japan

Regarding Japan’s national policy to raise the cashless payments ratio, the Cabinet Secretariat announced “Future Investment Strategy 2017” in June-2017, and the Ministry of Economy, Trade and Industry announced “Cashless Vision” in April-2018. Cashless Vision set a goal of raising the cashless payment ratio to 40% by 2025 when the Japan International Expo (Osaka – Kansai Expo) will be held, and in the future target 80%. **Promotion of cashless payments not only raises convenience for consumers, but it also addresses issues like the chronic labor shortage from the declining birthrate and aging society, improves productivity of SMEs, and helps to revitalize rural areas.** The graph on the top of the following page shows that Japan’s cashless payments ratio has risen from 21.3% in 2017 to 32.5% in 2021. **The other key takeaway from this graph is that credit cards are the largest beneficiary of ‘cashless.’**

Credit card business is growth business: METI annual trend of total transactions

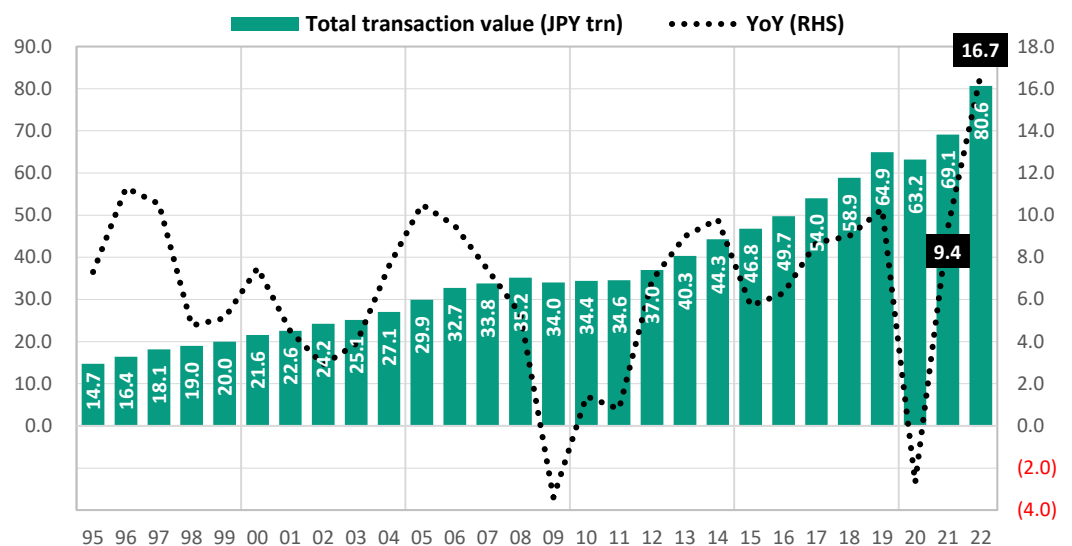

Source: compiled by SIR from “METI Monthly Survey of Specified Service Industries: Credit Cards.”



一般社団法人キャッシュレス推進協議会

Cashless Payments and Percentage of Private Final Consumption Expenditures

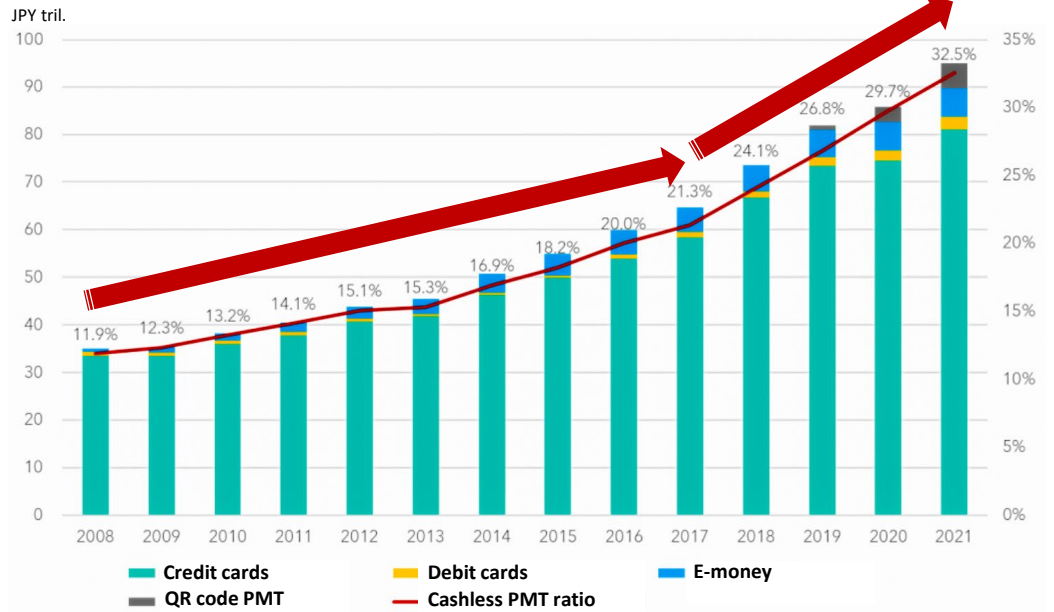

Source: Payments Japan Association (PJ), "Cashless Roadmap 2022," August 3, 2022 (in Japanese only) <https://paymentsjapan.or.jp/publications/20220803-roadmap2022/>

Japan is still a highly cash-based transaction society



Ratio of cashless payments in major world countries 2020

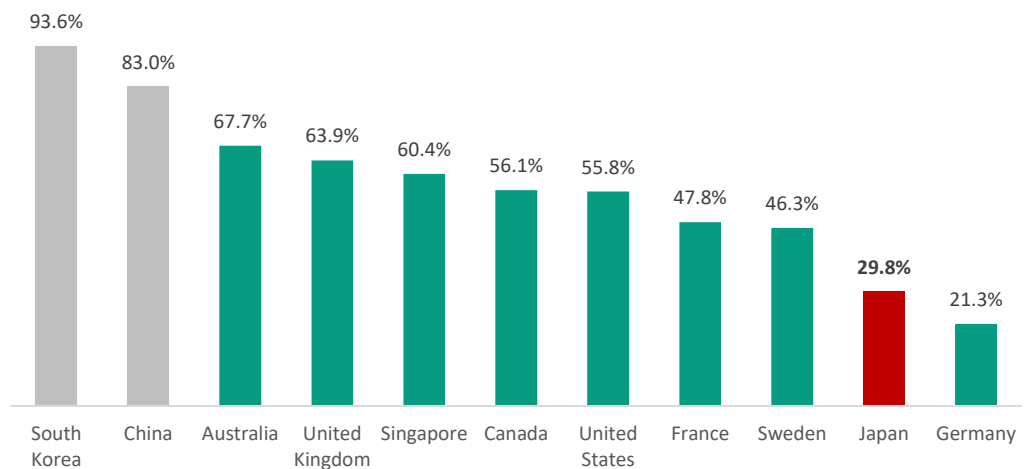

Average annual growth rate of cashless payments ratio over 5 years from 2015

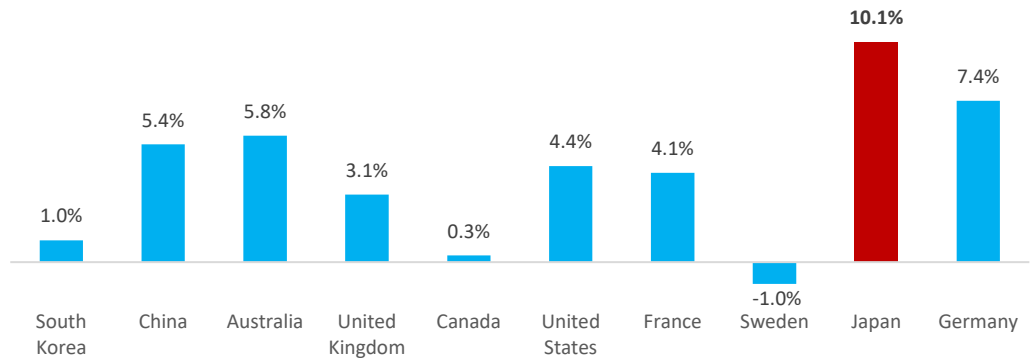

Source: compiled by SIR from Payments Japan Association "Cashless Roadmap 2022."

Breakdown of ¥6.9trn target payments of METI's Cashless Point Rebate Program by payment method (JPY trillion)

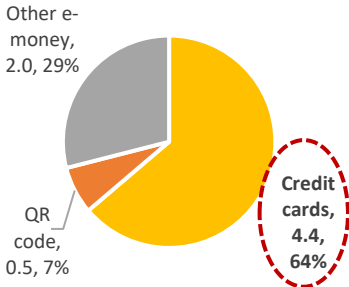

Source: METI



Credit cards are the biggest beneficiary of 'cashless'

MMD (mobile marketing data) Labs collaborated with VISA Worldwide Japan in conducting a survey regarding the government's Cashless Point Rebate Program from October 1, 2019 – June 30, 2020 (program was one measure aimed at mitigating the effect from the consumption tax hike 8% → 10% on Oct. 1 while promoting a LT goal). The survey targeted 50,000 valid respondents living in Japan between the ages of 20 – 69, during the period from December 13 through December 22, 2019. While the stock market often tends to find the array of new fintech payment technologies as more 'sexy,' the response of actual users of the Cashless Point Rebate Program overwhelming used credit cards as the preferred cashless payment method, citing a high level of trust, overall convenience and enhanced point systems.

Which cashless payment method did you use most often over the last one month?

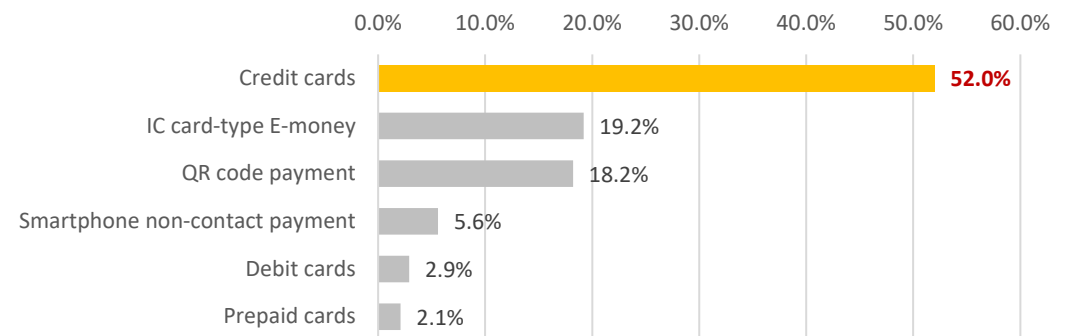

Source: compiled by SIR from "Survey of Actual Users of the Cashless Point Rebate Program for Consumers," MMD Labs and VISA Worldwide Japan, January 20, 2020.

Cashless Payment Methods



Credit card business is growth business – World

For 52 years since Sep-1970, Nilson Report has been the leading publication covering payment systems worldwide. According to new 5-year forecasts by Nilson Report (Jan-2023), UnionPay, Visa, Mastercard, American Express, JCB and Discover/Diners Club—the **global network cards—are projected to generate \$891bn in transactions in 2027, an increase of 42.3% versus \$626bn in 2022 (+7.3% CAGR)**. Card-present and card-not-present transactions will be generated by consumer and commercial credit, debit and prepaid cards, including QR code-based payments made by smartphones. **The key takeaway is that the global share of Asia-Pacific will rise from 46% → 49%**. In addition, Nilson Report estimates that issuers, merchants and acquirers lost \$32.34bn to fraud in 2021, \$11.91bn inside the US, and \$20.43bn outside the US.



Global Network Payment Card Purchase Transactions Projected Worldwide (USD bn)

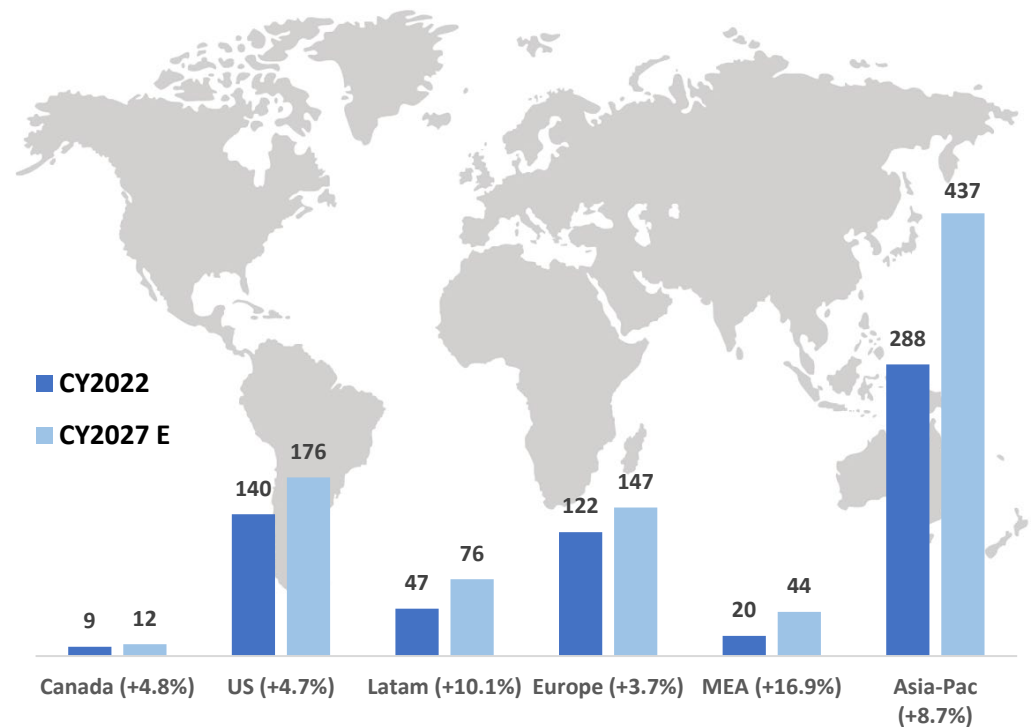

Source: compiled by SIR from Nilson Report, January 2023. 5-year CAGR by region shown in parentheses.

Trend of Credit Card Fraud Worldwide (USD bn), 7Y CAGR +8.6%

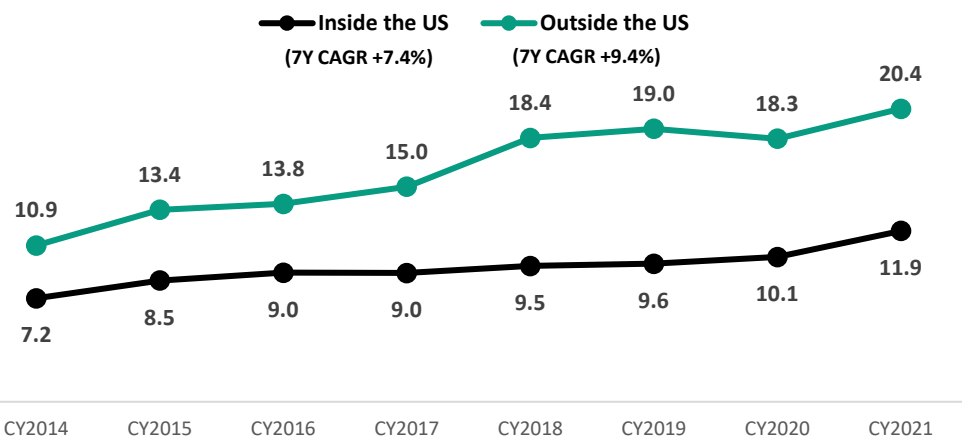

Source: compiled by SIR from Nilson Report, December 2022.



PART 2
BUSINESS



Founder Kazuhiko Adachi

Payment Solutions Business Domain for the Financial Services Sector

IWI's corporate group consists of the Company (reporting entity 4847), the parent Dai Nippon Printing (7912), and one affiliate, ODN Solution (Okinawa software outsourcing partner). IWI develops and maintains network connection systems for the financial services industry including credit card issuers, banks and brokerage firms, that process large amounts of data accurately and in real time, and operate reliably with zero fault, non-stop 24/7. In particular, the Company's core products, NET+1, which is on-premise FEP (front-end processor) system infrastructure comprised of hardware + software enabling network connectivity through gateway switching for card use authorization, and ACE Plus, an optional service which detects fraudulent card use through a rules-based fraud scoring engine which utilizes transaction data for machine learning, have established a dominant market share with the majority of credit card companies in Japan. **SIR estimates it has a 70-80% share in FEP system integration for the credit card industry**, with the notable exception of JCB, which is handled by TIS (3626). In addition, NET+1 has been adopted for the network control of some 25,000 ATMs installed in 7-Eleven and Ito-Yokado stores, train stations and airports nationwide.

In order to understand how IWI achieved such a high market share, it is necessary to review the Company's corporate history. IWI was founded in Dec-1984 for the purpose of importing, exporting, and sales of computer equipment, development of computer software, and associated consulting services. At that time, founder Kazuhiko Adachi was president of Tandem Computers Japan. Founded in 1974 in Cupertino California, Tandem Computers, Inc. was the leading manufacturer of fault-tolerant computer systems for ATM networks, banks, stock exchanges, and other similar commercial transaction processing applications requiring maximum uptime and zero data loss. It became part of the server division within Compaq in 1997, and it is now part of the server division of Hewlett Packard Enterprise (HPE).

Tandem's NonStop systems used a number of independent identical processors and redundant storage devices and controllers to provide automatic high-speed 'failover' in the case of a hardware or software failure. Then in 1980, Stratus Computer, Inc. (now Stratus Technologies, Inc.) emerged as a competitor to Tandem in fault tolerant computer servers and software with its proprietary Stratus VOS (Virtual Operating System), which is used to support high-volume transaction processing applications which require continuous availability. VOS is notable for being one of the few operating systems which runs on fully lock-stepped hardware. Lockstep systems are fault-tolerant computer systems that run the same set of operations at the same time in parallel. The redundancy (duplication) allows error detection and error correction. Stratus computers were resold worldwide from 1985 to 1993 under the IBM System/88 brand, gaining market share in online payment systems applications.

With the advent of the internet and IP, FEP systems perform vital functions linked to transaction switching in mission critical transaction environments such as banking, point-of-sale and security applications. **Kazuhiko Adachi recognized the huge potential for applications on online credit card payment transactions** of Stratus VOS, and over nearly 4 decades, IWI has established a dominant position in FEP systems development for most credit card companies in Japan, with the notable exception of JCB. IWI's flagship product Net+1 supports OS for Stratus and HP NonStop KERNEL. IWI's long history with these top makers of nonstop server systems as a preferred customer likely provides some background for the Company's profitable hardware sales business.

NET+1 is the de facto standard authorization center connection package with overwhelming market share

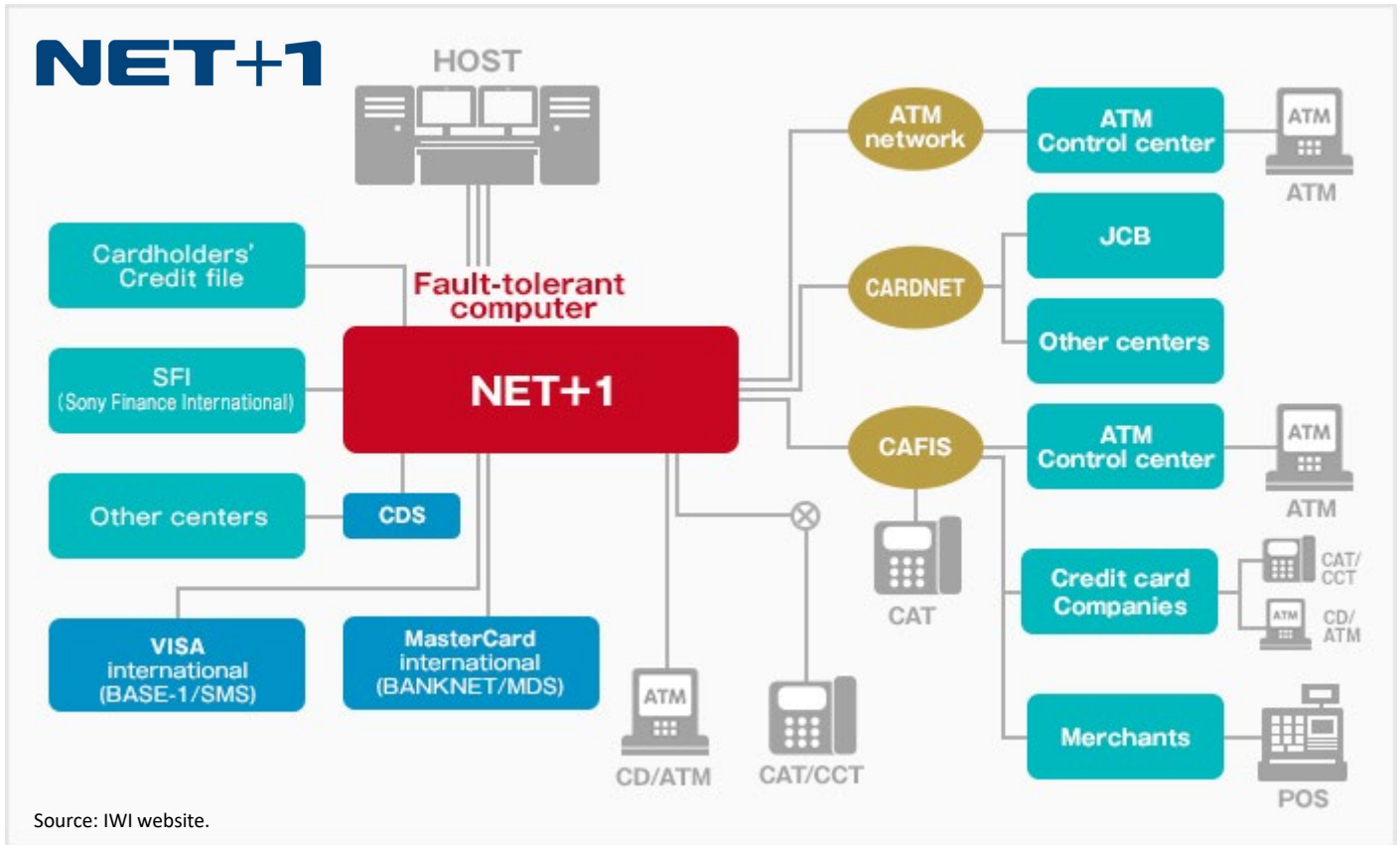

Optional service mitigates losses from credit card fraud

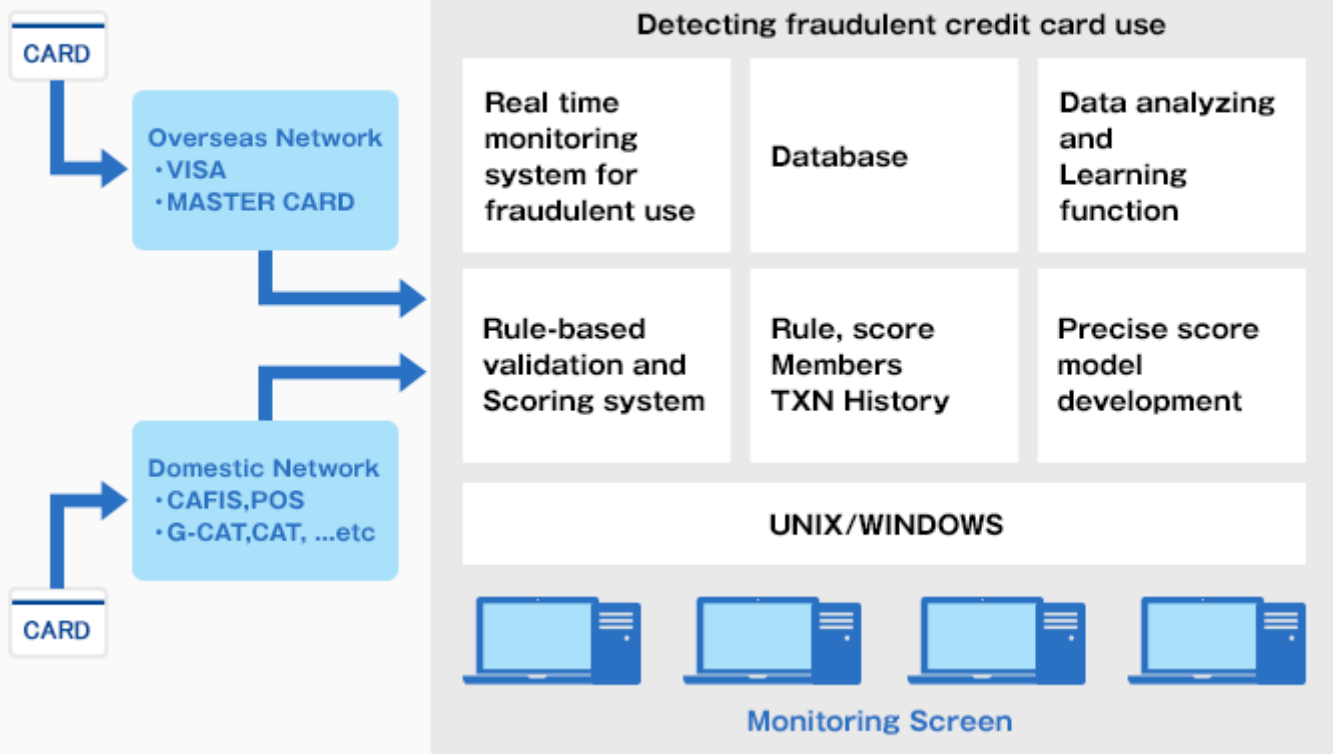

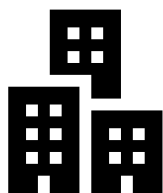

Trend of net sales by top three clients (JPY mn)

Client	FY2017.6	FY2018.6	CHG AMT	Main projects
① DNP	1,818	2,116	298	Smartphone payments, payment platforms, security products
② Credit card issuer	268	1,935	1,667	Credit card brand unification
③ Credit card issuer	377	647	270	Network gateway
Client	FY2018.6	FY2019.6	CHG AMT	Main projects
① DNP	2,116	1,952	(164)	Smartphone payments, payment platforms, security products
② Credit card issuer	406	684	278	FEP system, network gateway
③ Credit card issuer	1,935	674	(1,261)	Credit card brand unification
Client	FY2019.6	FY2020.6	CHG AMT	Main projects
① DNP	1,952	2,270	318	Smartphone payments, payment platforms
② Credit card issuer	684	832	148	Network gateway
③ System integrator	313	427	114	Network gateway
Client	FY2020.6	FY2021.6	CHG AMT	Main projects
① DNP	2,270	1,647	(623)	TSP system (Smartphone payment) , System operations (24/7), Payment Platform
② System integrator	531	1,213	682	FEP system and fraud detection for a new entrant
③ Credit card issuer	705	1,202	497	System development and hardware sales for FEP replacement
Client	FY2021.6	FY2022.6	CHG AMT	Main projects
① DNP	1,647	1,524	(123)	Tokenization Service system (for smartphone payment transaction) , Payment Platform, system operations (24/7)
② Credit card issuer	133	1,025	892	Hardware sales due to FEP system renewal
③ System integrator	1,213	891	(322)	Disaster recovery system for FEP system

Source: compiled by SIR from company IR results briefing materials.

*Payment Platform: system services operated by DNP enabling customers to launch cashless payment business.

*FEP (front-end processor) system: hardware + software enabling network connectivity for card authorization.

Protections for minority shareholders

Dai Nippon Printing Co., Ltd. is IW's parent with an ownership stake of 50.61% of shares outstanding (acquired by DNP in 2010), followed by founder Kazuhiko Adachi with 9.01%. The table above shows that over the last 5 years, annual sales from the parent have averaged roughly ¥1.9bn, nearly 20% of average annual total net sales of ¥10.9bn. IW has strict internal controls in place for monitoring all transactions with the parent at the Board member level, such that the interest of minority shareholders will not be compromised through preferential treatment of the parent and that all transactions are fair and represent the arm's length principle where both parties are independent and on equal footing to act in their own interest, without pressure or influence.



CWAT®

During the 1H results briefing, CEO Sato announced plans for a major CWAT upgrade, targeting affordability for medium-scale enterprises.



CEO Kunimitsu Sato



Cloud Service Functionality

- IPRETS:** Point rebate system
- IFINDS:** Card fraud detection
- IGATES:** Switching / gateway
- IOASIS:** Merchant acquiring

SaaS = software as a service is a software licensing and delivery model in which software is licensed on a subscription basis and is centrally hosted.

Information Security Solutions Business Domain

Following payment solutions business for the financial services sector, information security solutions business is IWI's second main business domain. IWI provides in-house and third-party products to prevent information leaks from inside corporate organizations and cyber attacks from outside for customers in all industries and business sectors. In-house developed product CWAT (cybercrime warning alert termination) prevents corporate information leaks from inside organizations by centrally monitoring and controlling both network and terminal operations within a company. In addition, IWI sells advanced cyber security products from overseas, with a focus on products from Israel, a leader in security solutions technology. **Information security business has been plagued by low profitability, and management continues to strive to establish an optimal, more profitable model.**

MTP priority strategy to establish a hybrid model adding SaaS cloud services

Due to the high growth in credit card business in Japan outlined in PART 1 as a result of national policy promoting the achievement of a cashless society and diversification of payment methods, as well as declining transaction charges (merchant discount rate shown in the exhibit on the bottom of P4), the business opportunity for IWI payment solutions business is expanding to include many new entrants starting up credit card business. One hurdle for these prospective customers is the high initial installation cost for an individual system under the FEP on-premise model below. The advantage of the cloud service model for the customer is an affordable scheme to lease the service, fixing running costs including maintenance. The advantage for IWI is securing a stream of recurring (stock) revenue going forward, which is scalable. Cloud services business turned profitable in FY22.6 on leading development costs peaking out and realizing efficiency gains on increased contracts.

Hybrid Model for Payment Solutions Business

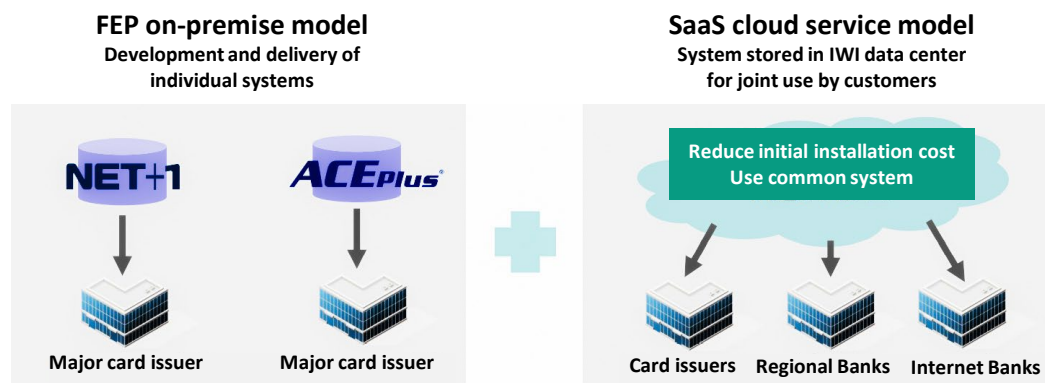

Overseas Expansion of Cloud Services

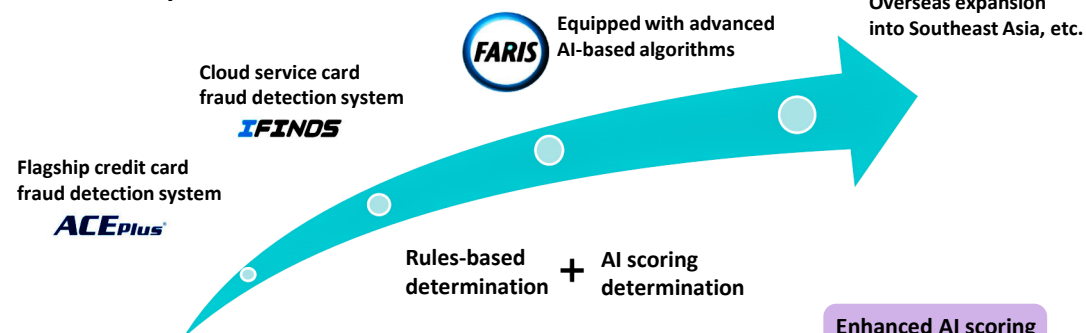

- Partnering with a US AI Venture to Adopt New AI Technology for FARIS

From September 2021, the AI engine "RIME" of AI security venture Robust Intelligence (headquartered in California), has been adopted for the FARIS scoring service. Started taking orders for the introduction of the system.

Source: company briefing materials Jan-2022.

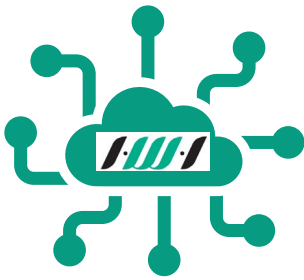

IGATES: Gateway/Switching

ASP cloud service that inherits payment network connectivity/switching function of flagship NET+1 (for online authorization, clearing, switching to destination networks). 24/7 operation that facilitates central management of secure connection support to multiple payment networks such as Visa (EAS), Mastercard (MIP), CAFIS, JCN, as well as ATM network, direct connection with issuers and internet connection for smartphone payment. Benefits of introduction relative to a separate on-premise FEP system include:

- Reduction of initial costs
- Reduction of client systems operation load for monitoring
- Peace of mind for maintaining operations w/o holding assets

IFINDS: Card Fraud Detection

ASP cloud service that inherits fraud detection function for unauthorized card use of flagship ACE Plus. Real-time checking of domestic and overseas credit requests based on pre-set rules and scoring functions (please refer to the diagram on P14 for features overview). Same benefits of introduction as IGATES.

IOASIS: Merchant Acquiring

ASP cloud service that provides core systems for rapid startup of acquiring operations such as external connection with international brands and cashless payment companies, authorization, and management of payment at affiliate merchant stores. Compatible with both Visa and Mastercard, it is PCI-DSS compliant, built in a robust datacenter and supports 24/7 operation. Benefits of introduction relative to a separate on-premise FEP system include:

- Reduction of initial costs
- Shorter time period until launching service
- Peace of mind for maintaining operations w/o holding assets

Priority initiative on porting flagship FEP applications to SaaS cloud services

One of the unavoidable characteristics of system integrator business is a certain amount of order volatility due to macroeconomic impacts on client capex. A focus initiative is switching to a recurring (stock) revenue model for cloud services. Relative to a high initial investment burden to install an in-house on-premise gateway switching system, the benefit to a new entrant is an affordable scheme to lease the service, fixing running costs including maintenance. As startup costs disappear and revenue gains critical mass, this business has begun to turn profitable. Descriptions of the three main cloud service applications are shown on the left, with **IOASIS for merchant acquiring being the only one of its kind available.**

Flagship on-premise FEP infrastructure solutions for credit card authorization



Recurring fee-based SaaS cloud solutions for credit card-related business



Source: IWI website.



IWI Corporate History Milestones

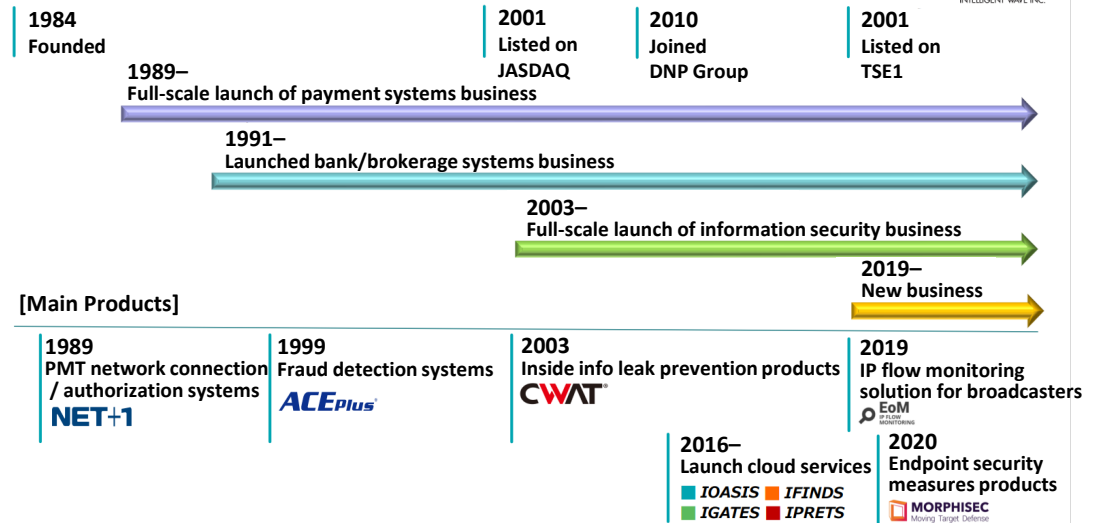

Summary Review of IWI Rolling Medium-Term Management Plans

IWI launched its “15 ALL” MTP in Aug-2021, targeting FY24/6 net sales of ¥15bn and OPM of 15%. The table below shows that year-1 OP and OPM came in significantly above initial forecasts, in part due to cloud services business turning profitable. **Rolling MTP 2025 reflects sustaining 10% topline grow and OPM above 15%.** The next 3 pages provide a summary of initiatives and progress of the previous and current MTPs.

IWI Rolling Medium-Term Management Plans

JPY mn, %	Previous Plan “15 ALL”				Revised Plan Rolling MTP 2025			
	FY21/6 act	FY22/6 init CE	FY23/6 MTP	FY24/6 MTP	FY22/6 act	FY23/6 init CE	FY24/6 MTP	FY25/6 MTP
Net sales	11,188	12,000	13,500	15,000	11,493	13,500	15,000	16,500
YoY (pct)	2.4	7.3	12.5	11.1	2.7	17.5	11.1	10.0
OP	1,131	1,320	1,750	2,250	1,520	1,800	2,250	2,500
OPM (%)	10.1%	11.0%	13.0%	15.0%	13.2%	13.3%	15.0%	15.2%

Source: compiled by SIR from company press release.

Roadmap to achieve “15 ALL” sales targets

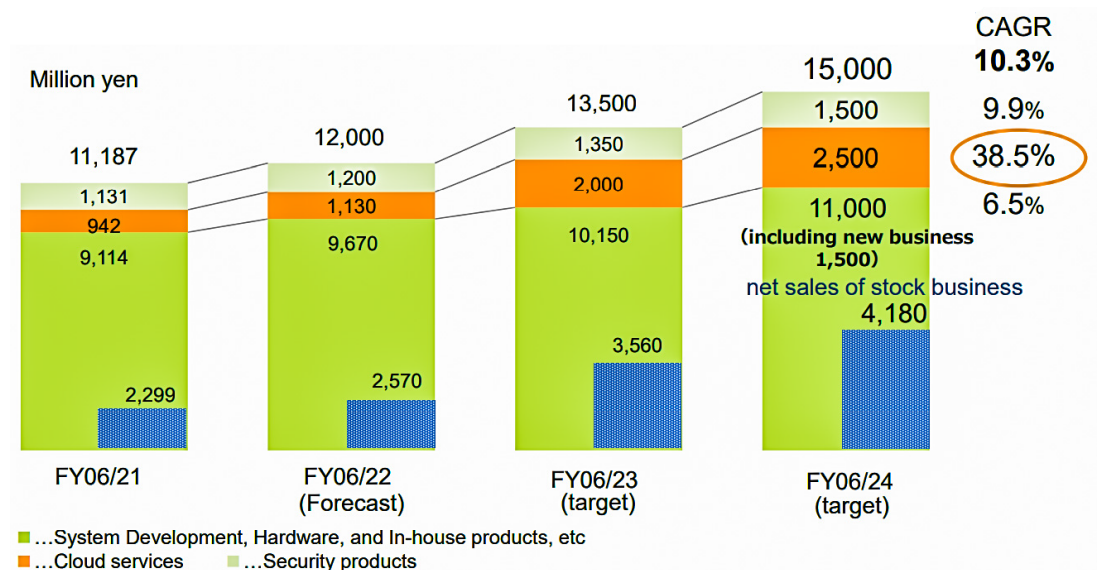

Source: excerpt from IR 4Q FY21/6 results briefing materials.



Review of MTP “15 ALL”



Yleisradio Oy, Finnish Broadcasting Company



While revenue for this solution is still small, it likely has good potential as terrestrial broadcasters move to offer new simultaneous livestream distribution service in response to viewers increasingly shifting away from the family room TV to mobile device platforms connected to the internet.

Previous Rolling MTP “15 ALL” Key Initiatives

The rolling MTP announced together with 21.6 Q4 financial results is targeting 3-year net sales CAGR of +10.3%, and 3-year OP CAGR of +25.8%. “15 ALL” refers to FY24/6 target net sales ¥15.0bn and OPM 15.0%.

① Hybrid IT infrastructure in mainstay payment business market

The benefit to prospective cloud service clients is an affordable scheme to lease the service, fixing the running costs including maintenance, with much shorter installation times and without the burden of adding to fixed assets. (please see P14: hybrid = on-premise flagship FEP + ASP cloud services).

② Expansion of business domain

Promotion of DX (digital transformation) leads many industries worldwide to requiring real-time and high-speed bulk data processing. IWI is expanding domestic EoM users (see explanation below) such as TV Asahi, JDS, QVC Japan, and the company won an order from Finland’s public broadcaster Yle, confirming business viability overseas. New business R&D is also examining potential solutions for connected cars and medical IoT devices, etc.

③ DNP Group Synergies

Operational Technology (OT) is hardware and software that detects or causes a change through the direct monitoring and/or control of physical devices, processes and events in the enterprise. Promote business synergy for DNP’s assets and IWI’s technology, starting with OT security for “smart factories” (DNP’s own plants, then client facilities).

EoM IP Flow Monitoring Solution for Broadcasting

In addition to cloud services, another promising new business area for the company is leveraging its experience and know-how in FPGA’s (Field Programmable Gate Arrays) to develop an EoM hardware/software solution for **broadcasting**. A big shift towards IP transmission is taking place as transferred data gets bigger with the spread of 4K/8K broadcasting. EoM monitors latency, jitter and packet drop rate to preserve broadcast data quality. This uses a low latency L1 switch with FPGA made by Arista Networks. **EoM visualizes and monitors the communication status of IP flows between bases in real time.** It achieves high-speed processing of large amounts of data by utilizing hardware with FPGAs, drawing on IWI’s strengths in network communications technology.

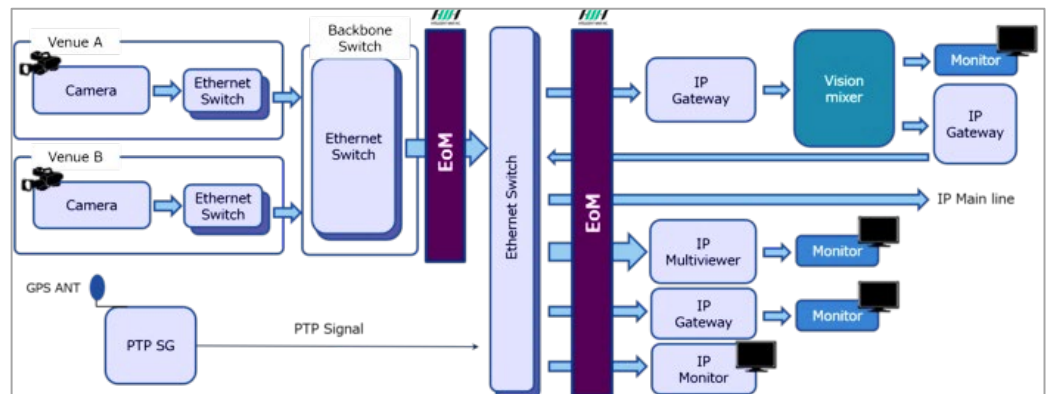

Source: excerpt from IR results briefing materials

Progress of MTP "15 ALL" and new targets for Rolling MTP 2025



Initiatives for sustainable growth included in the new Rolling MTP 2025

- ① Reinforcement and expansion of our business foundation
- ② Establishment of a foundation for human resources
- ③ Establishment of a foundation for co-creation

Progress of MTP "15 ALL" by sustainable growth initiatives

FY22/6 results

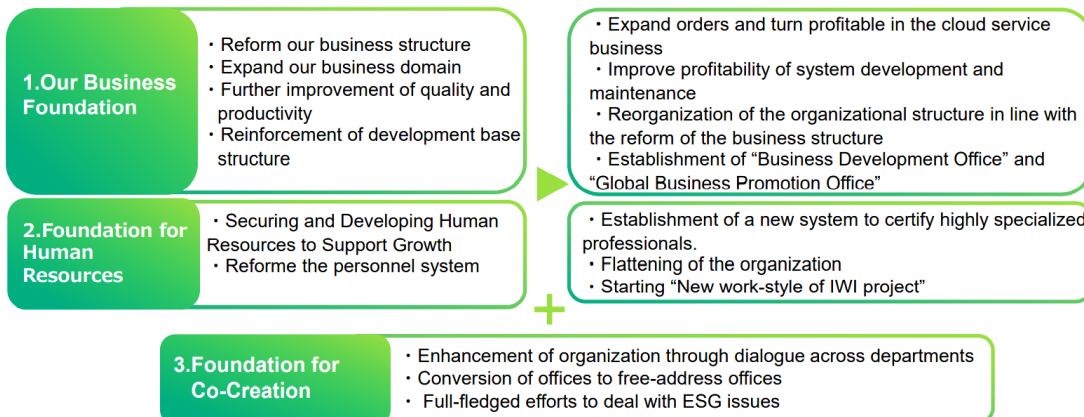

Strategies by Business Domain (see also business structure reforms on P16)

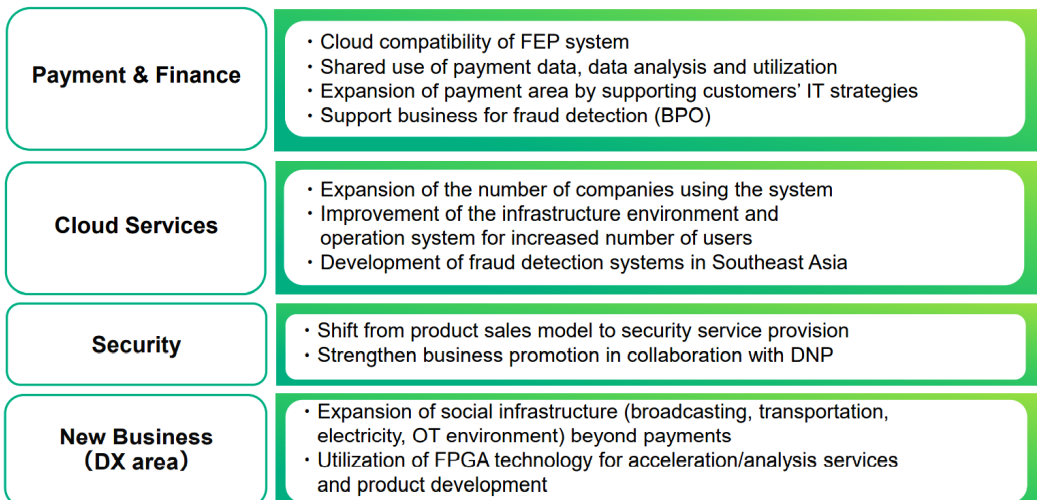

Roadmap to achieve Rolling MTP 2025 sales targets

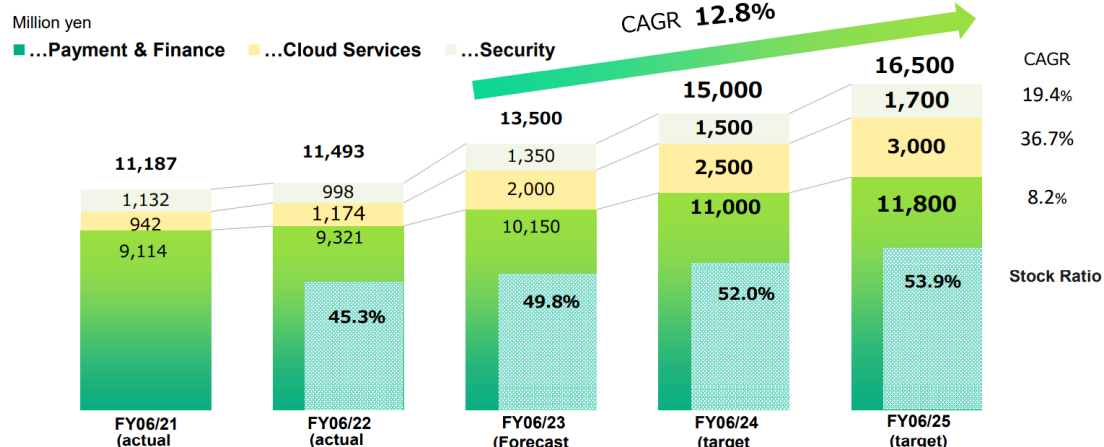

Source: excerpts from IR 4Q FY22/6 results briefing materials (includes top exhibit on P16).

★ Overview of Business Structure Reforms spelled out in Rolling MTP 2025

- Expansion of “stock*” type business centered on cloud services
- Cloud compatibility of FEP system, utilization of payment data
- Expansion of payment business domain by supporting customers' IT strategies
- Expansion of security business and New Businesses

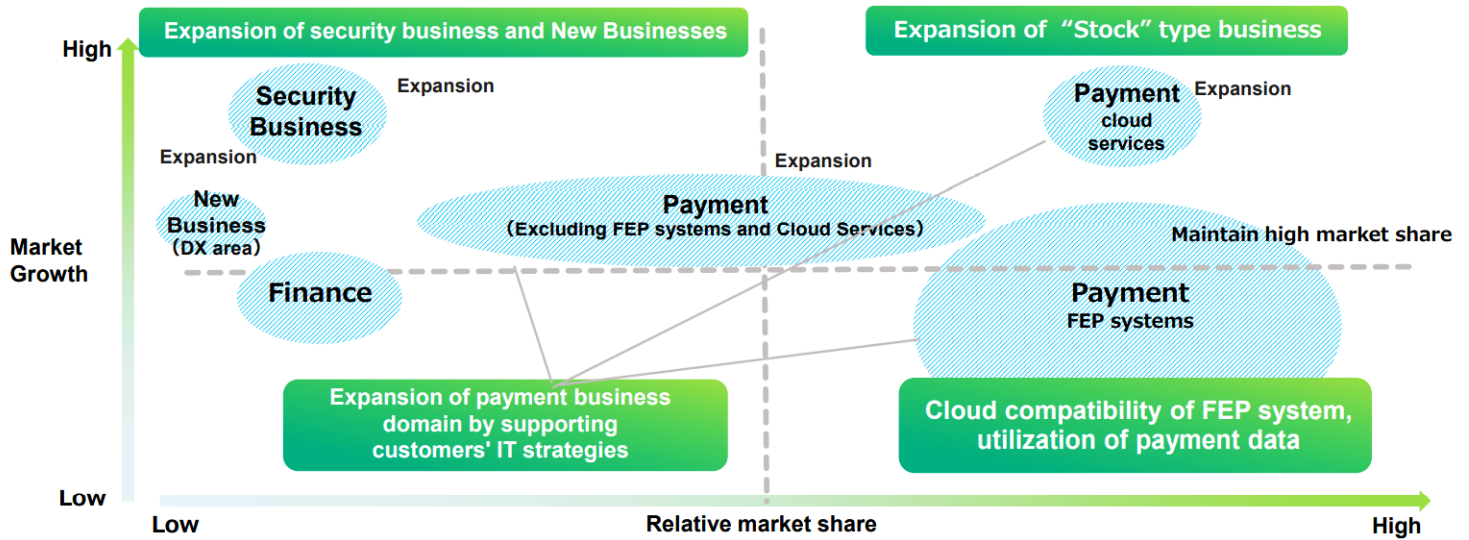

* “Stock” type: projects and contracts that can generate a certain amount of sales on a regular basis

Source: excerpt from IR results briefing materials

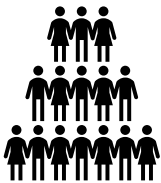

Securing and developing human resources to support growth

Management acknowledges that proactively nurturing human capital plays a vital role toward achieving long-term strategy initiatives and sustainability. By encouraging diversity in human resources and diverse workstyles, management aims to not only promote existing businesses, but also create an organization that will lead to the creation of new businesses. Key initiatives include 1) pursue workstyle and job satisfaction, 2) promote health and productivity management, and 3) promote success through diverse human resources. The company cites the virtuous cycle of employee advancement and social contribution, and that strategic investment in human capital will lead to achieving MTP initiatives and numerical targets.





PART 3
EARNINGS

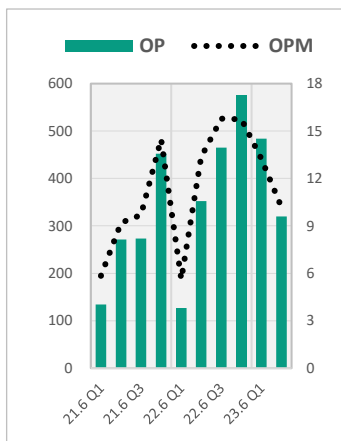
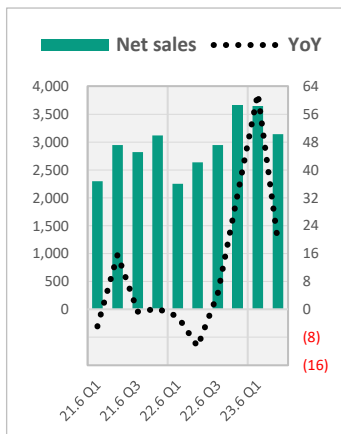

Source: compiled by SIR from TANSHIN financial statements. Units: JPY million, %

According to the Company, 1H cost overrun in cloud services was attributed to additional hiring to cope with customization needs for rapid growth in IOASIS, IWI's proprietary merchant acquiring service. Going forward, the Company plans to strengthen internal controls by assigning more direct oversight at the executive officer level. In addition, it will migrate some service to a public cloud data center to reduce costs.

Slight shortfall to 1H OP guidance

Growing pains that are treatable

SUMMARY

- IWI announced FY23/6 1H financial results at 15:30 on Wed. 2/01. 1H headline numbers were net sales ¥6,790mn (+39% YoY) and OP ¥803mn (+68% YoY), with OPM improving from 9.8% → 11.8%. However, relative to 1H initial guidance for net sales ¥6,800mn (+39% YoY) and OP ¥900mn (+88% YoY, OPM 13.2%), while net sales effectively achieved guidance, OP posted a slight shortfall. Actual 1H and 2Q-only results are shown in the table below. Despite 1Q net sales +62% YoY and OP +282% YoY (OPM 13.3%), 2Q net sales were +19% YoY and OP declined -9% YoY (OPM dipped to 10.2%).
- According to the financial results summary (TANSHIN), high growth in 1Q net sales was driven by the sharp increase in hardware sales due to FEP system upgrades for existing customers (included in third-party products below), an increase in the number of users of cloud services (included in own services), and large projects of system development for credit card companies (software development). Hardware sales during the 2Q returned to a more normalized level, and large projects of system development for credit card companies (software development) made the largest contribution to sales growth (top 3 in light green). Cloud services recorded 1H net sales of ¥881mn (+79% YoY) on the surge of orders last term, and 1H GP of ¥25mn (+108% YoY), but GP posted a shortfall to initial 1H guidance for ¥100mn due to increased investment to strengthen operational systems in line with the increased number of users for certain services. The Company is committed to turning this around through a fundamental review of the operational structure.
- The Company left initial FY23/6 full-term forecasts unchanged. Based on actual 1H results, implied 2H forecasts are net sales ¥6,710mn (+2% YoY) and OP ¥997mn (-4% YoY), with OPM of 14.9% (FY22/6 2H actual 15.8%). Growing pains in cloud services as the number of users ramps up is a manageable issue in SIR's view.

IWI FY23/6 1H and 2Q-only Non-consolidated Financial Results Summary

JPY mn, %	FY22/6	FY23/6	CHG	PCT	FY22/6	FY23/6	CHG	PCT
[J-GAAP]	1H act	1H act	AMT	YOY	2Q act	2Q act	AMT	YOY
Net sales	4,887	6,790	1,903	38.9	2,635	3,144	508	19.3
• Software development	1,979	2,347	368	18.6	1,090	1,300	210	19.3
• In-house products	285	111	(175)	(61.2)	157	27	(130)	(83.0)
• System service	16	15	(1)	(5.5)	8	8	0	4.3
• Third-party products	157	1,221	1,063	7.8x	128	183	55	43.1
FLOW total	2,438	3,693	1,255	51.5	1,382	1,518	135	9.8
• Maintenance	1,278	1,497	219	17.1	653	793	140	21.4
• Maintenance of 3P products	307	352	44	14.4	165	195	30	18.1
• Own services	625	998	373	59.7	316	506	190	60.2
• Other services	239	250	11	4.7	119	132	13	11.0
STOCK total	2,449	3,097	647	26.4	1,253	1,626	373	29.8
Gross Profit	1,497	2,121	623	41.6	877	986	109	12.4
GPM (%)	30.6%	31.2%			33.3%	31.4%		
Operating income	479	803	325	67.8	352	320	(32)	(9.1)
OPM (%)	9.8%	11.8%			13.4%	10.2%		
Ordinary income	500	824	324	64.9	375	344	(31)	(8.3)
Net income	338	558	220	65.1	255	233	(22)	(8.6)

Source: compiled by SIR from TANSHIN financial statements.

Note: in the past, IWI has provided initial guidance for sales by category. From this year, initial guidance for sales shown here is broken down by payment & finance, cloud service and security, in line with MTP focus business strategies.



IWI FY23/6 Non-Consolidated Initial Financial Forecasts

JPY mn, %	FY2022/06*			FY2023/06			PCT YoY
	1H act	2H act	FY act	1H CE	2H CE	FY CE	
Net sales	4,887	6,606	11,493	6,800	6,700	13,500	17.5
YoY	(6.9)	11.2	2.7	39.1	1.4	17.5	
• Payment & Finance	3,915	5,313	9,229	5,320	4,830	10,150	10.0
• Cloud Services	493	680	1,173	880	1,120	2,000	70.5
• Security	478	612	1,090	600	750	1,350	23.9
Operating income	479	1,040	1,519	900	900	1,800	18.5
ratio to sales	9.8%	15.7%	13.2%	13.2%	13.4%	13.3%	
Ordinary income	500	1,056	1,556	920	920	1,840	18.3
ratio to sales	10.2%	16.0%	13.5%	13.5%	13.7%	13.6%	
Net income	338	717	1,055	640	640	1,280	21.3
ratio to sales	6.9%	10.9%	9.2%	9.4%	9.6%	9.5%	

Source: compiled by SIR from company FY23/6 1Q IR results briefing materials.

*Payment & Finance and Security restated for last term (from 4Q briefing) to reflect partial reclassification in FY23/6.

IWI FY23/6 1H Non-Consolidated Financial Results and Variance vs Initial CE

JPY mn, %	FY22/6	FY23/6	AMT	PCT	FY23/6	FY23/6	AMT
	1H act	1H act	CHG	YoY	1H CE	1H act	CHG
Net sales	4,887	6,790	1,903	38.9	6,800	6,790	(10)
YoY	(6.9)	38.9			39.1	38.9	
• Payment & Finance	3,915	5,393	1,478	37.8	5,320	5,393	73
<i>by product/service category</i>							
System development	2,369	2,840	471	19.9	2,820	2,840	20
Maintenance	725	816	91	12.6	800	816	16
In-house products/services	377	218	(159)	(42.2)	170	218	48
Third party (hardware etc.)	442	1,517	1,075	243.2	1,530	1,517	(13)
<i>by business domain</i>							
FEP / fraud detection	2,660	3,625	965	36.3			
Payment systems etc.	904	1,377	473	52.3			
Finance, other	350	389	39	11.1			
• Cloud Services	493	881	388	78.7	880	881	1
• Security	478	514	36	7.5	600	514	(86)
Gross profit	1,497	2,121	623	41.6			
ratio to sales	30.6%	31.2%					
SG&A expenses	1,018	1,317	299	29.3			
ratio to sales	20.8%	19.4%					
Operating income	479	803	325	67.8	900	803	(97)
YoY	18.0	67.8			88.0	67.8	
ratio to sales	9.8%	11.8%			13.2%	11.8%	
Ordinary income	500	824	324	64.9	920	824	(96)
ratio to sales	10.2%	12.1%			13.5%	12.1%	
Net income	338	558	220	65.1	640	558	(82)
ratio to sales	6.9%	8.2%			9.4%	8.2%	
New orders	7,516	6,459	(1,057)	(14.1)			
YoY	33.8	(14.1)					
Backlogs	7,963	9,233	1,270	15.9			
YoY	40.0	15.9					

Source: compiled by SIR from TANSHIN financial statements and IR results briefing materials.



Even with solid growth in 1H sales, backlogs remain at a high level on healthy orders

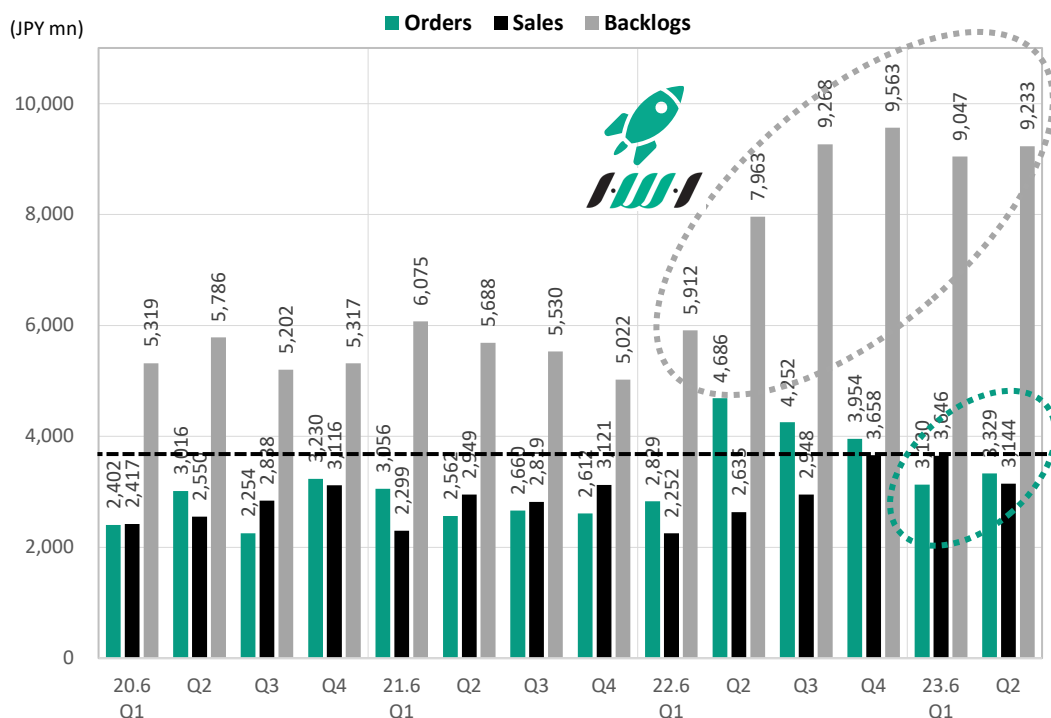

Source: compiled by SIR from TANSHIN financial statements and company IR results briefing materials.

Despite the shortfall to 1H OP guidance, business momentum remains strong

- A key takeaway from the graph above is that after stripping out the several large new orders for IOASIS in the 1Q and 2Q last term shown below and described on the following page, 1Q and 2Q orders this term are maintaining healthy levels, with 2Q up sequentially, in turn resulting in backlogs also rising sequentially.
- The Company acknowledges that it will be difficult to make up the 1H shortfall in cloud service gross profit due to cost overruns from additional hiring to meet the needs for customization work on IOASIS. However, it is worth noting that the cause has been clearly identified, and steps are being taken to address this issue.

Cloud Service Business

JPY mn, %	FY2021/06				FY2022/06				FY2023/06			
	1Q	2Q	3Q	4Q	1Q	2Q	3Q	4Q	1Q	2Q	3Q CE	4Q CE
New orders	133	73	79	483	1,000	1,876	273	311	507	822		
Backlogs	1,934	1,762	1,609	1,853	2,611	4,236	4,210	4,141	4,214	4,589		
Net sales												
• Plan	224	235	235	246	240	248	296	343	430	450	470	650
• Actual	224	246	232	239	243	250	299	380	434	447		
Gross profit												
• Plan	(14)	(10)	(29)	(22)	(18)	18	46	33	33	67	62	138
• Actual	(37)	(12)	(28)	(3)	(19)	31	84	25	(4)	29		
No. of customers												
• IOASIS	5	5	5	5	5	6	7	10	10	10	10	11
• IGATES	2	4	4	4	4	4	5	6	6	7	7	9
• IFINDS	3	3	3	3	3	3	3	3	4	5	5	8
• IPRETS	1	1	1	1	1	1	1	1	1	1	1	1

Source: compiled by SIR from IR results briefing materials.



Cloud Functionality Service

- IPRETS:** Point rebate system
- IFINDS:** Card fraud detection
- IGATES:** Switching / gateway
- IOASIS:** Merchant acquiring

Cloud services: number of customers by service lines: targeting 29 by 4Q FY23/6

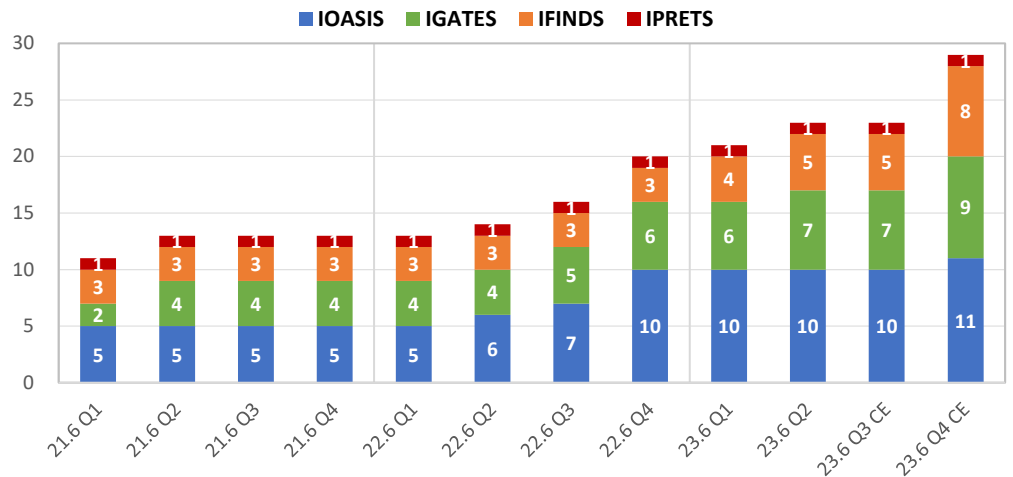

Cloud GP turned profitable on declining fixed costs, higher operating efficiency (JPY mn)

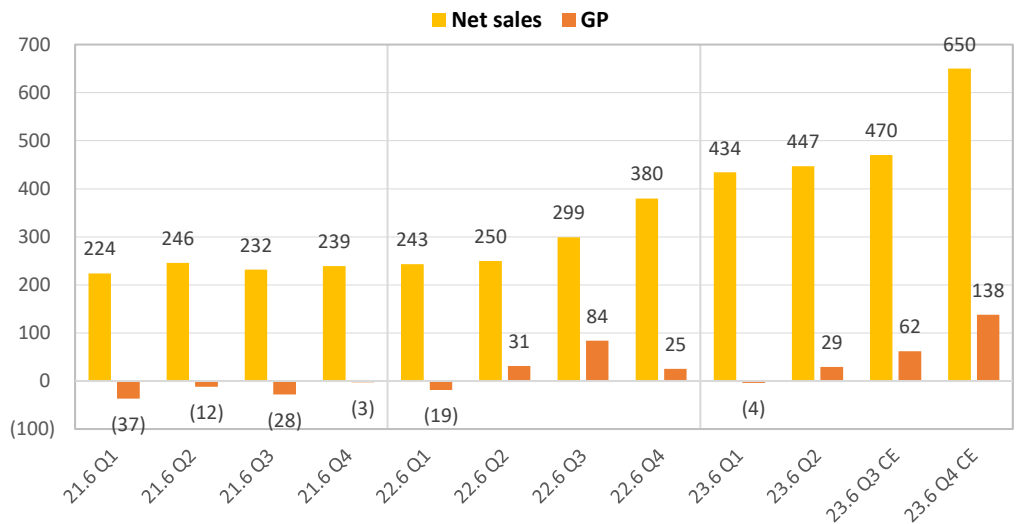

Annual Trend (JPY mn)

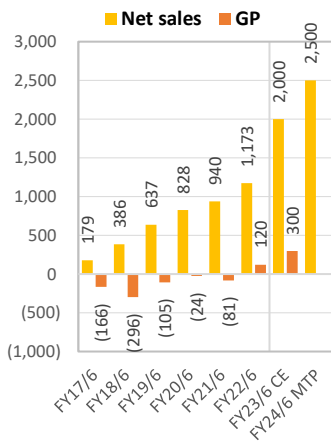

1H orders for cloud services

In 1H FY22/6, there were several large new orders for IOASIS, and this term growth is expected to come mainly from additional development for existing customers. IFINDS and IGATES are receiving strong inquiries (1 major client for IGATES, preparing to sign). During the 2H, IOASIS will see 1 new customer, with 1 inquiry for additional features. IGATES and IFINDS are expected to add 2 new each.

Brisk orders steadily extending visibility out to FY24/6 MTP target sales (JPY mn)

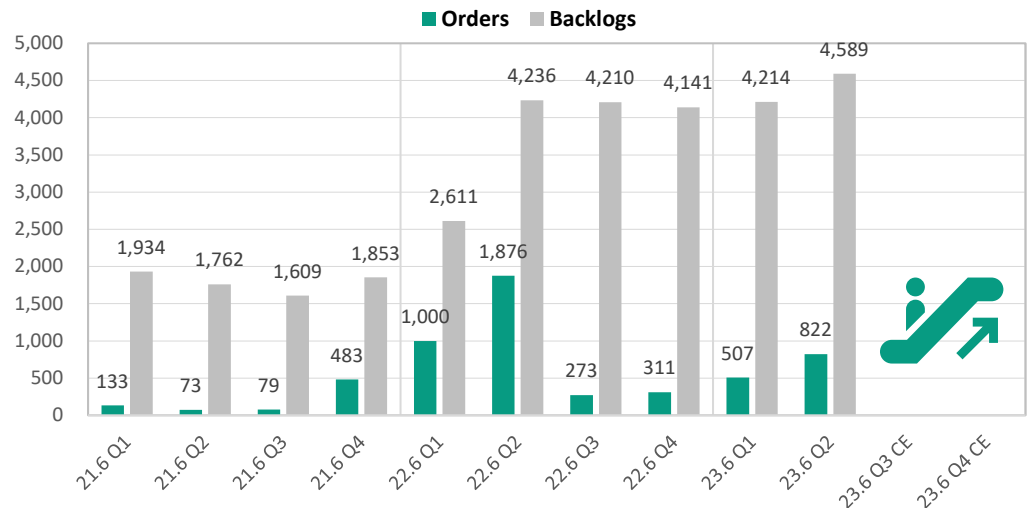

Source: compiled by SIR from IR briefing materials.

Summary of Key Initiatives during 1H FY2023/06

<p>Payment & Finance</p>	<ul style="list-style-type: none"> - Collaborated with JCB to strengthen measures to prevent card fraud throughout the industry-wide. Launched the first project. - Expanding business domain into peripheral systems area by supporting IT strategies of major credit card company client. - Expanding system development with major credit card company client under lab contract
<p>Cloud Services</p>	<ul style="list-style-type: none"> - Strengthening management structure to improve profitability - Increasing inquiries about our fraud detection service due to damage expansion for card fraudulent use - Migration to public cloud in some service for reduce operating costs
<p>Security</p>	<ul style="list-style-type: none"> - Promoting the synergy with DNP (including sales for DNP use) - Upgrading the major version and developing additional features of the in-house product 'CWAT'
<p>New business (Digital Transformation area)</p>	<ul style="list-style-type: none"> - Developing new service relating to National Language Processing - Promoting overseas sales of the solution for broadcasters 'EoM' (acquired the patent in the US and planning to conduct POC in several companies in Europe)

Source: excerpt from IR results briefing materials



COLLABORATIVE INITIATIVES FOR CARD FRAUD PREVENTION

● The Company announced on October 28, 2022 that IWI and JCB are launching a “Security Consortium” to promote the advancement of fraud detection by sharing know-how and data across the industry to combat card fraud of the entire credit card industry. The Consortium aims to put the system into practical use by the end of FY2023, starting with credit card companies that have already introduced IWI's fraud detection system.



世界にひとつ。あなたにひとつ。

● The Company announced on November 1, 2022 that IWI and PKSHA, known for its AI algorithms, will jointly develop “FARIS Shared Scoring Service Powered by PKSHA Security” for fraud prevention. This new advanced service will jointly share fraud data among card issuers who use the service. The joint scoring service is scheduled to go live in June 2023 and be rolled out to card issuers in due course.





INTELLIGENT WAVE INC.

PART 4
INVESTORS



Performance and Valuations:
SESSA Smart Charts

- ✓ Volume contracted sharply over FY21/6, which we believe was likely due to lack of participation by foreigners on concerns about not meeting TSE1 listing criteria for tradable market cap (free float) over ¥10bn.
- ✓ The P/E is now on a 21% discount to its historical average, and EV/EBITDA is on a 20% discount to its historical average.
- ✓ **The dividend yield of 2.82% is now 21% above its historical average.**

+3.55%	▲	128.34
+12.3%	▲	548.23
+5.34%	▲	254.23
-7.89%	▼	321.56
+5.97%	▲	100.08
+2.13%	▲	584.23
+6.43%	▲	765.90
-11.6%	▼	120.34
+23.1%	▲	893.23
+5.56%	▲	128.90
-3.67%	▼	432.1
-11.3%	▲	765.2
2.54%	▲	432.1

3-Year Weekly Share Price, 13W/26W/52W MAs, Volume and Valuations

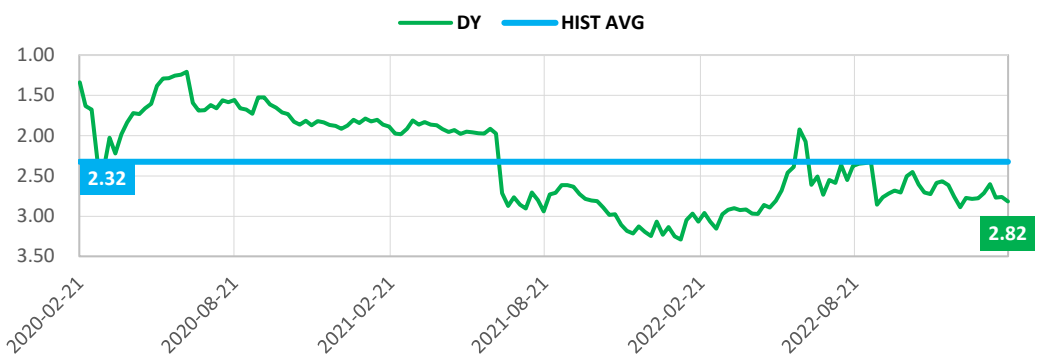
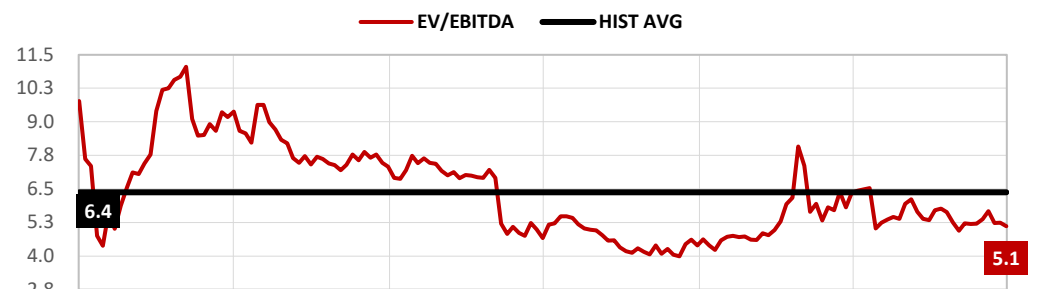
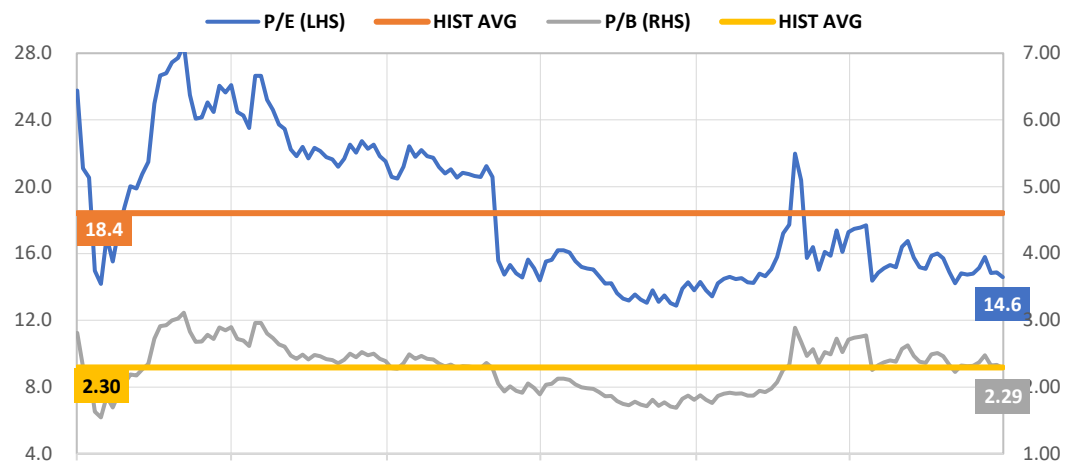

Source: compiled by Sessa Partners from SPEEDA historical earnings and price data. Valuations calculated based on CE.



Analyst's view

Structural profitability improvement is the driver

- ✓ A focus initiative is switching to a recurring (stock) revenue model for cloud services. As startup costs disappear and revenue gains critical mass, cloud services business has turned profitable.
- ✓ As can be seen in the lower right-hand monthly stock price chart, the share price appears to have put in a triple bottom just below 500 in Mar-2018, Mar-2020 (COVID) and in Jan-2022, and risk appears balanced on the upside considering high profit growth expected going forward...
- ✓ The ratio of foreign shareholders dropped 55% from 4.84% at the end of June 2020 to 2.19% at the end of June 2021. The subsequent collapse of volume put valuations at extremely compelling levels **just as profits are taking off.**



CEO Kunimitsu Sato



3-Year Weekly Relative Performance: IWI lagged for 1½ years due to confusion over the TSE Prime Market listing, just as profits are taking off

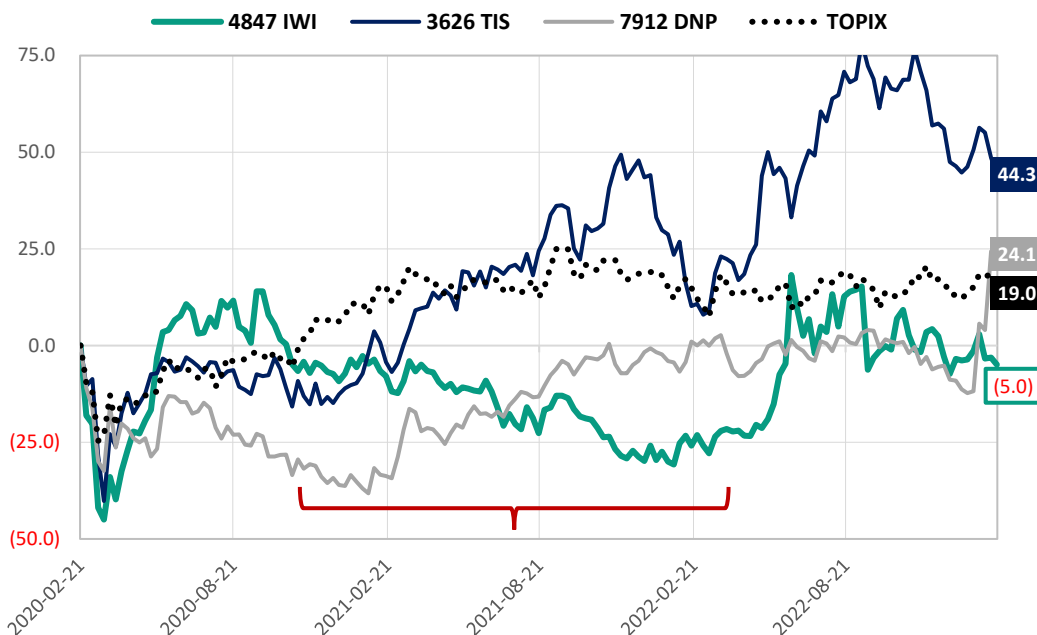

Trend of Shareholder Rebates: target payout ratio hiked to 40% or more

JPY mn, JPY, %	FY2017/6	FY2018/6	FY2019/6	FY2020/6	FY2021/6	FY2022/6	FY2023/6
[J-GAAP]	NC act.	NC act.	NC act.	NC act.	NC act.	NC act.	init CE
Profit (loss)	547	377	684	762	841	1,056	1,280
EPS (¥)	20.78	14.36	25.99	29.00	31.98	40.16	48.70
DPS (¥)	7.00	7.00	9.00	10.00	13.00	17.00	20.00
Total net assets	5,648	5,715	6,373	6,983	7,568	8,039	
Equity ratio	66.4	64.7	63.5	66.2	67.9	63.1	
ROE	10.3	6.6	11.3	11.4	11.6	13.5	
Payout ratio	33.6	48.8	34.6	34.5	40.6	42.3	41.1
DOE	3.5	3.2	3.9	3.9	4.7	5.7	

Source: compiled by SIR from TANSHIN financial statements.

10-Year Monthly Share Price, 6M/12M/24M MAs, Volume. Formed a triple bottom?

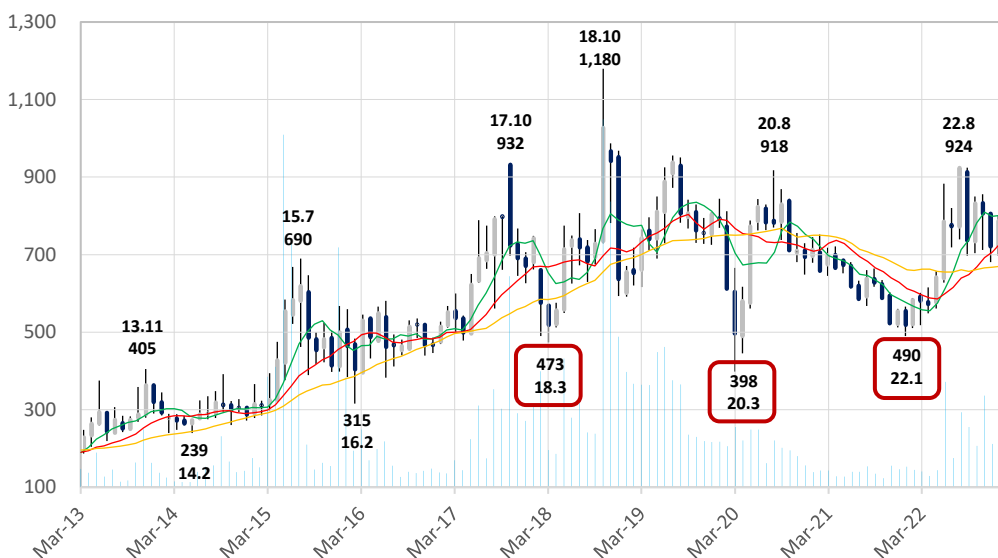

Source: compiled by SIR from SPEEDA historical price data.

Supplement: Non-consolidated Balance Sheets

	Thousands of yen	
	Fiscal year ended June 30, 2022	2Q FY ended December 31, 2022
Assets		
Current assets		
Cash and deposits	3,932,647	4,336,685
Notes and accts receivable - trade, and contract assets	2,723,400	1,694,930
Securities	300,381	300,084
Inventories	313,359	354,403
Other	1,004,436	907,953
Total current assets	8,274,224	7,594,057
Non-current assets		
Property, plant and equipment	706,395	872,649
Intangible assets		
Software	1,640,255	1,859,529
Other	409,584	515,519
Total intangible assets	2,049,839	2,375,048
Investments and other assets		
Investment securities	916,484	927,768
Other	793,824	813,101
Total investments and other assets	1,710,309	1,740,869
Total non-current assets	4,466,543	4,988,568
Total assets	12,740,768	12,582,625
Liabilities		
Current liabilities		
Notes and accounts payable - trade	940,780	415,805
Income taxes payable	331,611	353,200
Advances received	1,885,029	1,939,496
Provision for bonuses	289,341	281,798
Provision for bonuses for directors	45,885	30,293
Other	543,134	727,141
Total current liabilities	4,035,783	3,747,737
Non-current liabilities		
Provision for retirement benefits	552,279	576,724
Provision for retirement benefits for directors	22,565	10,945
Asset retirement obligations	87,554	87,588
Other	3,421	2,817
Total non-current liabilities	665,820	678,075
Total liabilities	4,701,603	4,425,813
Net assets		
Shareholders' equity		
Capital stock	843,750	843,750
Capital surplus	573,099	573,099
Retained earnings	6,199,843	6,311,039
Treasury stock	(26,712)	(26,712)
Total shareholders' equity	7,589,980	7,701,176
Valuation and translation adjustments		
Valuation difference on available-for-sale securities	449,184	455,635
Total valuation and translation adjustments	449,184	455,635
Total net assets	8,039,164	8,156,812
Total liabilities and net assets	12,740,768	12,582,625

Source: compiled by SIR from YUHO financial statements.

IWI Corporate History

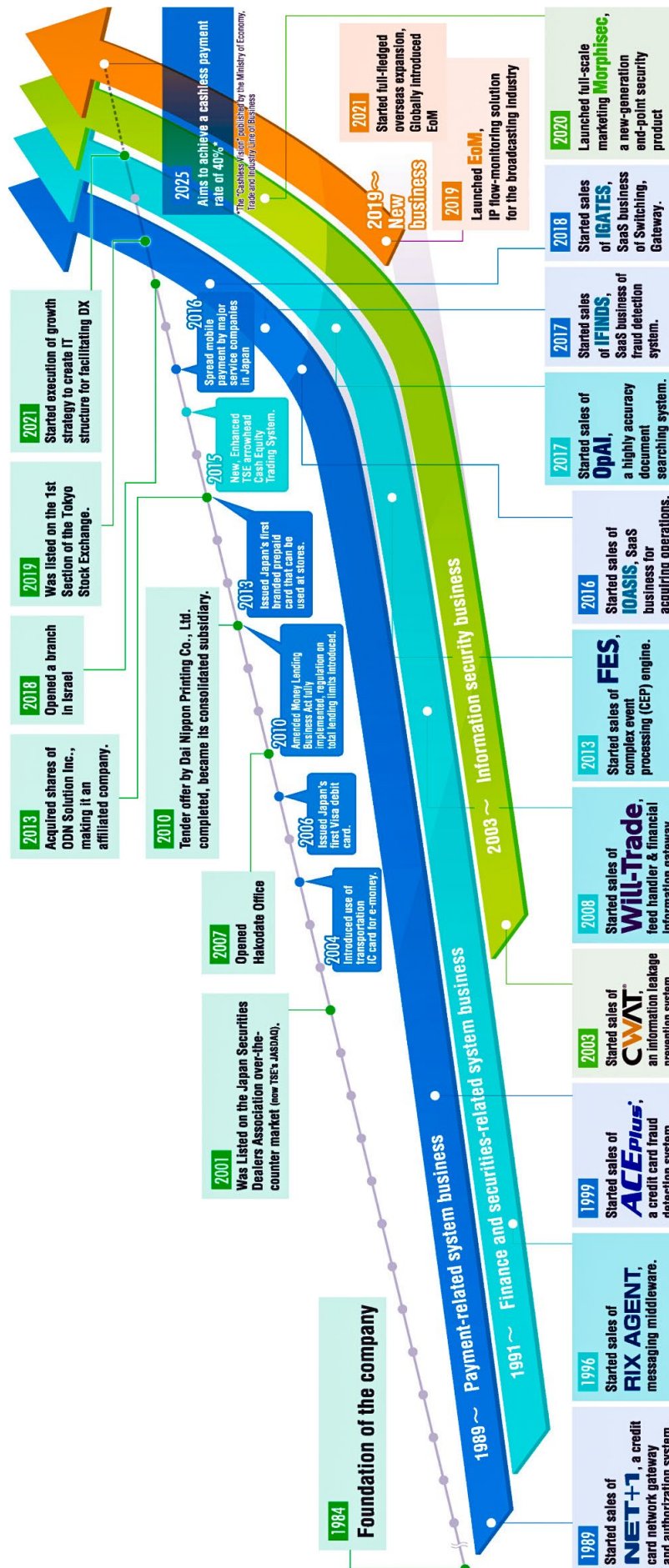

Source: Company website

LEGAL DISCLAIMER

This report is intended to provide information about the subject company, and it is not intended to solicit or recommend investment. Although the data and information contained in this report have been determined to be reliable, we do not guarantee their authenticity or accuracy.

This report has been prepared by Sessa Partners on behalf of the concerned company for which it has received compensation. Officers and employees of Sessa Partners may be engaged in transactions such as trading in securities issued by the company, or they may have the possibility of doing so in the future. For this reason, the forecasts and information contained in this report may lack objectivity. Sessa Partners assumes no liability for any commercial loss based on use of this report. The copyright of this report belongs to Sessa Partners. Modification, manipulation, distribution or transmission of this report constitutes copyright infringement and is strictly prohibited.



Sessa Partners Inc.

#5a i-o Azabu, 2-8-14
Azabujyuban, Minato-ku, Tokyo
info@sessapartners.co.jp